



Jet and Centrifugal Pumps



Contents

Pump type	Code	Page
Stainless steel jet pump series	GPS-BJZ	1
Submersible pressure systems		
Submersible jet pump	GPS-X-AJE	2
Submersible horizontal multi-stage pump	GPS-X-AMO	3
Submersible vertical multi-stage pump	GPS-X-AMV	4
Peripheral centrifugal pumps		
Peripheral pump	GPS-KFM	5
Jet pumps		
Stainless steel jet pump up to 1.6Hp	GPS-CA/CAM	6
Cast iron jet pump up to 1.3Hp	GPS-CA/CAM	7
Cast iron twin impeller jet pump 1.5 to 2.0Hp	GPS-CA/CAM	8
Deepwell pump down to 50m 1.5 to 2.0Hp	GPS-AP/APM	9
Horizontal multistage pumps		
Stainless steel multi-stage pump up to 1.3Hp	GPS-SM	10
Multi-stage centrifugal pump 0.8 to 4.0 Hp	GPS-RS/RSM	11
Centrifugal pumps		
High head single impeller pump, flows up to 300 l/m	GPS-C/CM	12
High head twin impeller pump, flows up to 400 l/m	GPS-2C/2CM	13
Low head - medium flow pump, flows up to 500 l/m	GPS-CB/CBM	14
Low head - high flow pump, flows up to 1500 l/m	GPS-CB/CBM	15
Standardised centrifugal pump	GPS-CS	16
Spa and pool pumps		
Pool pump	GPS-MPC/MPCM	24
Spa pump	GPS-SPA/SPAM	26
Cast iron pool pump	GPS-NMP/NMPM	28
Dirty water centrifugal and submersible pumps		
Self priming vortex pump	GPS-A/AM	29
Drainage submersible pumps	GPS-TS/TSN	30
Vortex submersible pumps	GPS-TF	31



Stainless steel jet pump series GPS-BJZ

Application

Self-priming stainless steel pressure system. Able lift water up to 6 metres depth and work even with some aeration in the water. The control system provides automatic operation switching the pump on as water is demanded from a tap and switching the pump off once the flow stops. Suitable for drinking water.

Operating conditions

- Max. working pressure 6 bar
- Liquid temperature up to 40°C
- Ambient temperature up to 40°C
- Total suction lift up to 6m
- Continuous duty

Motor

- Two-pole induction motor(2850 rpm)
- Insulation class F
- Protection IP54

Materials

- Pump body - stainless steel
- Motor support - aluminium
- Impeller - stainless steel
- Diffuser - noryl
- Pump flange - stainless steel
- Shaft with rotor - stainless steel
- Mechanical seal - carbon/ceramic

Warranty

- 12 months from date of purchase

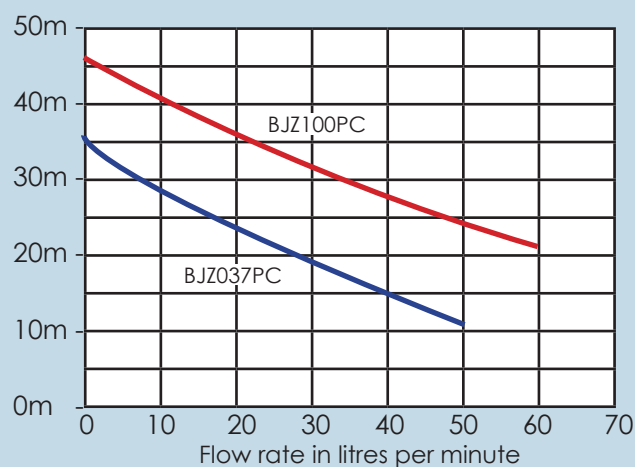

Technical data GPS-BJZ

Type	Voltage	Power P ₂		Capacity (litres per minute)							
				L/m	0	10	20	30	40	50	60
		kW	Hp	Total Head (metres)							
				H (m)							
BJZ037PC	230	0.37	0.5	37	30	24	20	16	12		
BJZ100PC	230	0.75	1.0	46	40	36	32	28	24	21	

*BJZ Pumps have 12 month warranty only.

Submersible jet pump GPS-X-AJE

Application

Self-priming jet water pumps with a very high hydraulic performance and a considerable pressure capacity. Able to operate at suction lifts of up to 8 metres, and work perfectly even in aerated water. Suitable for submerged or surface installation. Typically this pump is used to pressurise the water supply into to small dwellings or pump water from retention tanks into reuse systems from underground water storage tanks.

Suitable for use as a domestic pressure system in-conjunction with or without a small pressure tank a electronic flow control system automatically switches the pump on and off as water is demand request.

Special Features

- Built in pump control system, no external control system required for automatic operation
- Built in run dry protection
- Built in self test sequence every 72 hours
- Adjustable starting pressure, preset to 2.2bar

Operating conditions

- Liquid temperature between 2 and 37°C
- Ambient temperature up to 40°C
- Total suction lift up to 8m
- Pumped liquid to be free of solids and abrasives

Motor

- Two pole induction motor (2850rpm)
- Water cooled, by pumped liquid
- Insulation - class F
- Protection IP68

Materials

- Pump body – stainless steel 304
- Motor body – stainless steel 304
- Back bracket – stainless steel 304
- Shaft – stainless steel 416
- Impeller – stainless steel 304
- Diffuser – techno-polymer
- Mechanical seal – silicon/silicon
- Power cable – 10m
- Electronic board with microprocessor
- Flow sensor with cobalt Samario magnets

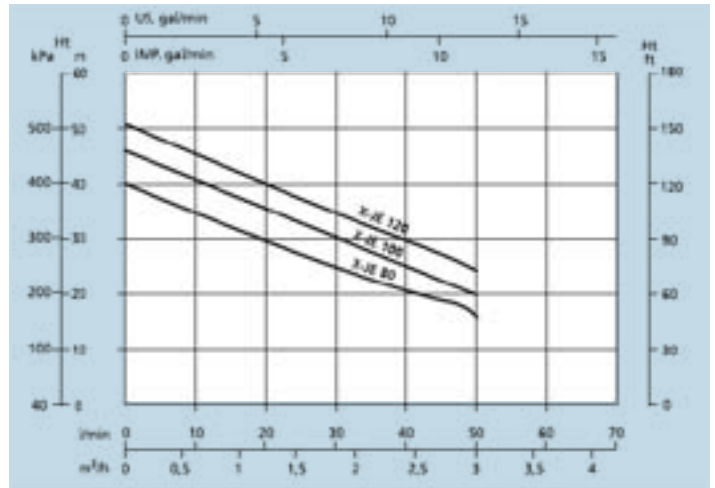

Technical Data GPS-X-AJE

Type	Voltage	Power P ₂		Capacitor		Full load current Amps	Capacity (litres per minute)																																							
		kW	Hp	uF	Volt		L/m	0	10	20	30	40	50	60																																
X-AJE080	230	0.60	0.8	16	450	4.5	<table border="1"> <thead> <tr> <th colspan="8">Total Head (metres)</th> </tr> <tr> <th>H (m)</th> <th>40</th> <th>33</th> <th>30</th> <th>24</th> <th>20</th> <th>15</th> <th>5</th> </tr> </thead> <tbody> <tr> <td>47</td> <td>40</td> <td>35</td> <td>30</td> <td>25</td> <td>20</td> <td>15</td> <td>5</td> </tr> <tr> <td>51</td> <td>45</td> <td>40</td> <td>34</td> <td>30</td> <td>24</td> <td>15</td> <td>8</td> </tr> </tbody> </table>								Total Head (metres)								H (m)	40	33	30	24	20	15	5	47	40	35	30	25	20	15	5	51	45	40	34	30	24	15	8
Total Head (metres)																																														
H (m)	40	33	30	24	20	15									5																															
47	40	35	30	25	20	15	5																																							
51	45	40	34	30	24	15	8																																							
X-AJE100	230	0.75	1.0	18	450	5.3																																								
X-AJE120	230	0.90	1.2	20	450	5.9																																								

Submersible horizontal multi-stage pump GPS-X-AMO

Applications

Horizontal self-priming multi-stage pumps which can be used in both domestic and industrial situations. Suitable for submerged or surface installation. Must be used with clean water, without abrasive or suspended parts. Typically this pump is used to pressurise the water supply into a medium to large dwelling from an underground water storage tank.

Can be used for domestic purposes, such as fountains and water-plays, sprinkling and sliding irrigations; also for industrial applications such as washings, treatment of drinking water and cooling systems.

Special Features

- Built in pump control system, no external control system required for automatic operation
- Built in run dry protection
- Built in self test sequence every 72 hours
- Adjustable starting pressure, preset to 2.2bar

Operating conditions

- Liquid temperature between 2 and 37°C
- Ambient temperature up to 40°C
- Total suction lift up to 8m
- Pumped liquid to be free of solids and abrasives



Motor

- Two pole induction motor (2850rpm)
- Water cooled
- Insulation class F
- Protection IP 68

Materials

- Pump body – stainless steel 304
- Motor body – stainless steel 304
- Back bracket – stainless steel 304
- Shaft – stainless steel 416
- Impeller – stainless steel 304
- Diffuser – techno-polymer
- Mechanical seal – silicon/silicon
- Power cable – 10m
- Electronic board with microprocessor
- Flow sensor with cobalt Samario magnets

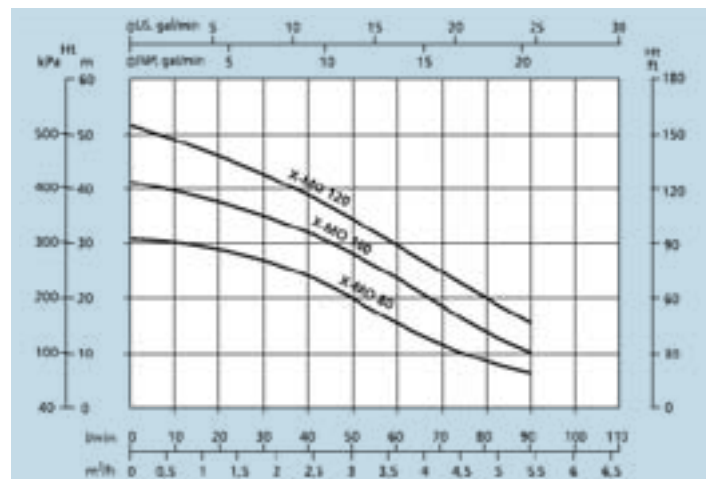

Technical data GPS-X-AMO

Type	Voltage	Power P ₂		Capacitor		Full load current	Capacity (litres per minute)									
							L/m	0	30	40	50	60	70	80	90	100
								Total Head (metres)								
X-AMO080	230	0.60	0.8	16	450	4.8	H (m)	33	28	23	20	18	13	10	7	
X-AMO100	230	0.75	1.0	18	450	6.0		42	35	30	28	24	18	15	10	
X-AMO120	230	0.90	1.2	20	450	7.2		52	43	40	35	30	25	20	15	8

Submersible vertical multi-stage pump GPS-X-AMV

Application

Vertical self-priming multi-stage pumps which can be used in both domestic and industrial situations. Suitable for submerged or surface installation. Must be used with clean water, without abrasive or suspended parts. Typically this pump is used to pressurise the water supply into large dwellings from an underground water storage tanks.

Powerful and suited for use in confined spaces. Can be used for civil pressurizing, fountains and water-plays, sprinkling and sliding civil irrigations; and for industrial uses, such as washings, treatment of drinking water and cooling systems.

Special Features

- Built in pump control system, no external control system required for automatic operation
- Built in run dry protection
- Built in self test sequence every 72 hours
- Adjustable starting pressure, preset to 2.2bar

Operating conditions

- Liquid temperature between 2 and 37°C
- Ambient temperature up to 40°C
- Total suction lift up to 8m
- Pumped liquid to be free of solids and abrasives

Motor

- Two pole induction motor (2850rpm)
- Water cooled
- Insulation class F
- Protection IP 68

Materials

- Pump body – stainless steel 304
- Motor body – stainless steel 304
- Back bracket – stainless steel 304
- Shaft – stainless steel 416
- Impeller – stainless steel 304
- Diffuser – techno-polymer
- Mechanical seal – silicon/silicon
- Power cable – 10m
- Flow sensor with cobalt Samario magnets

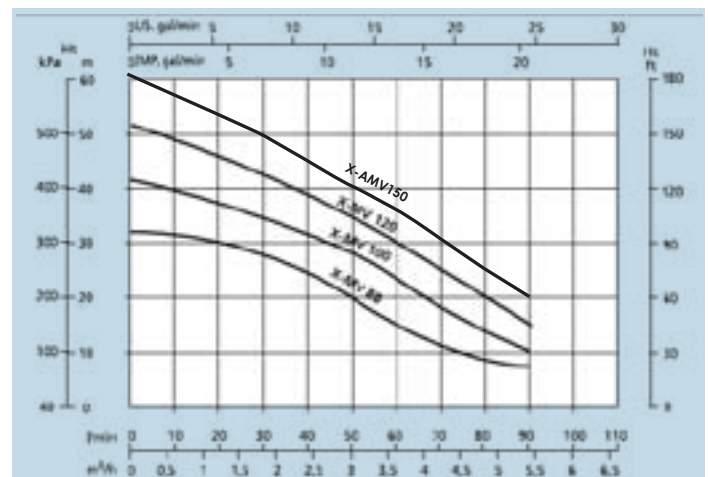

Technical data GPS-X-AMV

Type	Voltage	Power P ₂		Capacitor		Full load current	Capacity (litres per minute)									
		kW	Hp	uF	Volt		Amps	L/m	0	30	40	50	60	70	80	90
X-AMV080	50Hz	0.60	0.8	16	450	4.8	Total Head (metres)									
X-AMV100	230	0.75	1.0	18	450	6.0	H (m)	33	28	23	20	18	13	10	7	
X-AMV120	230	0.90	1.2	20	450	7.2		42	35	30	28	24	18	15	10	
X-AMV150	230	1.10	1.5	25	450	7.6		52	43	40	35	30	25	20	15	8
								63	49	45	41	36	31	25	20	13

Peripheral pump GPS-KFM

Application

These volumetric water pumps are able to offer high pressures in relation to comparatively low power consumption and have particularly steady performance curves. They are suitable for domestic pressure boosting installations.

The KFM pumps can be used to increase the system pressure for automatic water distribution by pressure tanks or by electronic flow control units. For the correct functioning of the pump, use only clean water or non-aggressive liquids, without sand or other solid impurities.



Operating conditions

- Liquid temperature up to 60°C
- Ambient temperature up to 40°C
- Total suction lift up to 7 m
- Continuous duty

Connections

- Suction 1" BSP
- Discharge 1" BSP

Motor

- Two-Pole induction motor (2850 rpm)
- Insulation class F
- Protection IP 44

Materials

- Pump body - cast iron
- Motor support - cast iron
- Pump body cover - brass
- Impeller - brass
- Shaft with rotor - stainless steel
- Mechanical seal - carbon ceramic

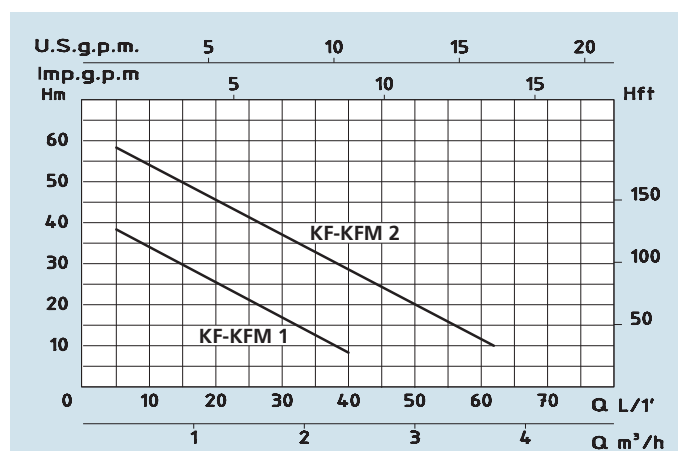

Technical data GPS-KFM

TIPO - TYPE		POTENZA NOMINALE NOMINAL POWER P2		POTENZA ASSORBITA INPUT POWER P1	AMPERE		Q = PORTATA - CAPACITY										
Monofase Single-phase	Trifase Three-phase	HP	kW	kW	Monofase Single-phase	Trifase Three-phase	Prevalenza manometrica totale in m.C.A. - Total head in meters w.c.										
							m³/h	0,3	0,6	1	1,2	1,5	1,8	2,1	2,4	3	3,6
230V-50Hz	230/400V-50Hz				1 x 230V	3 x 400V	lt/1	5	10	16	20	25	30	35	40	50	60
KFM 1	KF 1	0,5	0,37	0,55	2,9	1,3	H	38	35	30	26	21	17	13	8		
KFM 2	KF 2	0,8	0,7	0,9	3,8	1,9	(m)	58	54	50	45	42	38	33	28	20	12

Stainless steel jet pump GPS-CA/CAM



Application

Self-priming jet water pumps with very high hydraulic performance and considerable pressure capacity. Able to pump up to 8 metres depth and work perfectly even in aerated water. Suitable for drinking water. Can be used with electronic pressure control units and pressure tanks.

Operating conditions

- Max. working pressure 6 bar (CAM 80-85-88)
- Max. working pressure 8 bar (CAM 95-98-198)
- Liquid temperature up to 35°C
- Ambient temperature up to 40°C
- Total suction lift up to 8m
- Continuous duty

Motor

- Two-pole induction motor(2850 rpm)
- Insulation class F
- Protection IP44

Materials

- Pump body - stainless steel
- Motor support - aluminium
- Impeller - (CAM 80-85) noryl
- Impeller - stainless steel
- Diffuser - noryl
- Pump flange - stainless steel
- Shaft with rotor - stainless steel
- Mechanical seal - carbon/ceramic

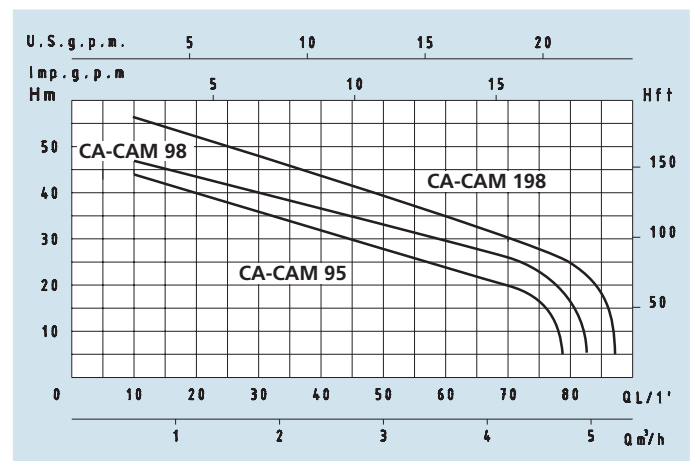
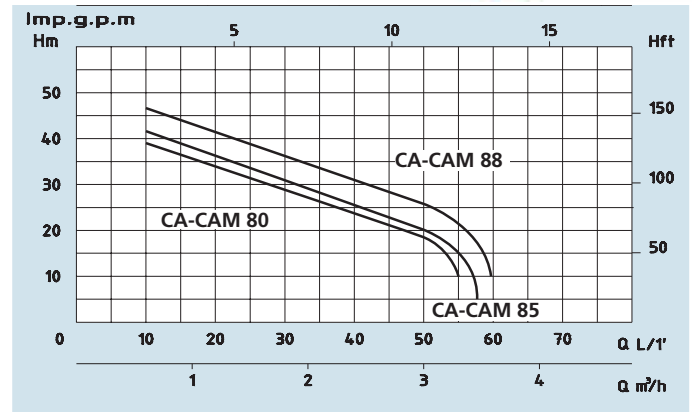

Technical data GPS-CA/CAM

TIPO - TYPE		POTENZA NOMINALE NOMINAL POWER P2		POTENZA ASSORBITA INPUT POWER P1	AMPERE		Q = PORTATA - CAPACITY										
Monofase Single-phase	Trifase Three-phase	HP	kW	kW	Monofase Single-phase	Trifase Three-phase	m³/h	0,6	0,9	1,2	1,5	1,8	2,1	2,4	2,7	3	3,6
230V-50Hz	230/400V-50Hz				1 x 230V	3 x 400V	lt/1	10	15	20	25	30	35	40	45	50	60
CAM 80	CA 80	0,8	0,6	0,8	3,8	1,9	H (m)	38	36	34	32	29	27	24	22	19	
CAM 85	CA 85	0,9	0,7	0,9	4	2,1		42	40	36	33	31	28	26	24	20	
CAM 88	CA 88	1	0,75	1,1	5	2,5		46	43	40	38	35	32	30	29	26	

TIPO - TYPE		POTENZA NOMINALE NOMINAL POWER P2		POTENZA ASSORBITA INPUT POWER P1	AMPERE		Q = PORTATA - CAPACITY										
Monofase Single-phase	Trifase Three-phase	HP	kW	kW	Monofase Single-phase	Trifase Three-phase	m³/h	0,6	0,9	1,2	1,5	1,8	2,4	3	3,6	4,2	4,8
230V-50Hz	230/400V-50Hz				1 x 230V	3 x 400V	lt/1	10	15	20	25	30	40	50	60	70	80
CAM 95	CA 95	1	0,75	1,1	5	2,5	H (m)	44	40	38	36	34	30	27	24	20	
CAM 98	CA 98	1,3	1	1,3	5,8	2,8		47	45	44	41	39	35	32	28	26	
CAM 198	CA 198	1,6	1,1	1,6	7,5	3,5		56	53	50	48	46	42	36	34	32	25

Cast iron jet pump GPS-CA/CAM

Application

Self-priming jet water pumps with very high hydraulic performance and considerable pressure capacity. Able to operate at suction lifts of up to 8 metres, and work perfectly even in aerated water.

Suitable for use as a domestic pressure system using either pressure tank system or electronic flow control systems to automatically switch the pump on and off.



Operating Conditions

- Max. working pressure 6 bar
- Liquid temperature up to 35°C
- Ambient temperature up to 40°C
- Total suction lift up to 8m.
- Continuous duty

Connections

- Suction 1" BSP
- Discharge 1" BSP

Motor

- Two pole induction motor (2850 rpm)
- Insulation Class F
- Protection IP44

Materials

- Pump body - cast iron
- Motor support - aluminium
- Impeller - noryl
- Diffuser - noryl
- Pump flange - stainless steel
- Shaft with rotor - stainless steel
- Mechanical seal - carbon/ceramic

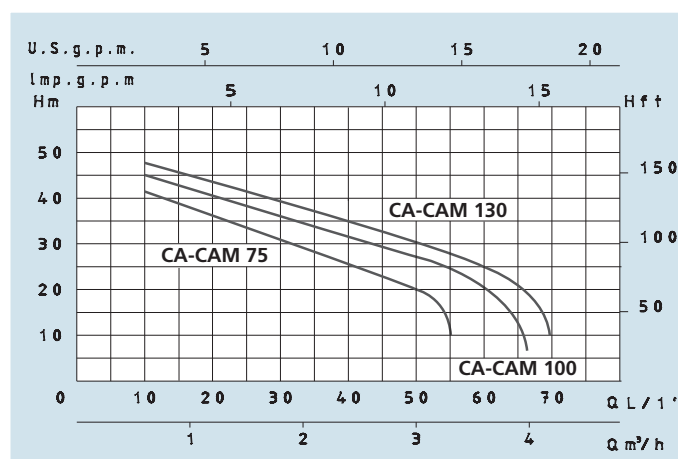

Technical data GPS-CA/CAM

TIPO - TYPE		POTENZA NOMINALE NOMINAL POWER P2		POTENZA ASSORBITA INPUT POWER P1	AMPERE		Q = PORTATA - CAPACITY										
Monofase Single-phase	Trifase Three-phase	HP	kW	kW	Monofase Single-phase	Trifase Three-phase	m³/h	0,6	0,9	1,2	1,5	1,8	2,1	2,4	2,7	3	3,6
230V-50Hz	230/400V-50Hz				1 x 230V	3 x 400V	lt/1	10	15	20	25	30	35	40	45	50	60
CAM 75	CA 75	0,8	0,6	0,8	3,8	1,9	H (m)	42	38	35	32	28	25	24	22	20	
CAM 100	CA 100	1	0,75	1,1	5	2,5		45	43	40	38	35	33	30	29	26	22
CAM 130	CA 130	1,3	1	1,3	5,8	2,8		47	44	42	40	38	36	34	32	28	25

Prevalenza manometrica totale in m.C.A. - Total head in meters w.c.

Cast iron twin impeller jet pump GPS-CA/CAM

Application

Self-priming jet water pumps with a very high hydraulic performance and a considerable pressure capacity due to jet-assisted twin impeller design. Able to operate at suction lifts of up to 8 metres, and work perfectly even in aerated water.

Suitable for use as a domestic pressure system using either pressure tank system or electronic flow control systems to automatically switch the pump on and off.

As the motor size increases, a pressure tank becomes the preferred option for pump control.

Operating conditions

- Max. working pressure 8 bar
- Liquid temperature up to 35°C
- Ambient temperature up to 40°C
- Total suction lift up to 8m.
- Continuous duty

Connections

- Suction 1 1/2" BSP
- Discharge 1" BSP

Motor

- Two-pole induction motor
- Insulation class F
- Protection IP44

Materials

- Pump body - cast iron
- Motor support - cast iron
- Impeller - brass
- Diffuser - noryl
- Pump support - cast iron
- Shaft with rotor - stainless steel
- Mechanical seal - carbon/ceramic

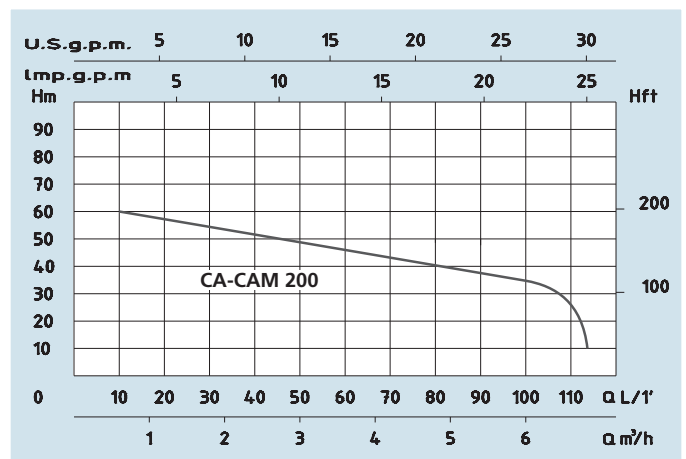
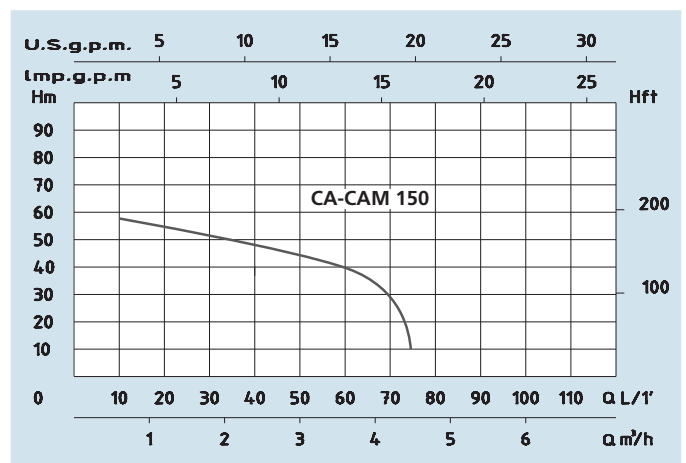

Technical Data GPS-CA/CAM

TIPO - TYPE		POTENZA NOMINALE NOMINAL POWER P2		POTENZA ASSORBITA INPUT POWER P1	AMPERE		Q = PORTATA - CAPACITY											
Monofase Single-phase	Trifase Three-phase	HP	kW	kW	Monofase Single-phase	Trifase Three-phase	m³/h	0,6	1,2	1,8	2,4	3	3,6	4,2	4,8	5,4	6	
230V-50Hz	230/400V-50Hz				1 x 230V	3 x 400V	lt/1	10	20	30	40	50	60	70	80	90	100	
CAM 150	CA 150	1,5	1,1	1,5	7	3	H (m)	58	55	51	47	42	40	35				
CAM 200	CA 200	2	1,5	2	9,3	4,2		60	57	53	50	47	35	44	40	38	35	

Deep well pump GPS-AP/APM

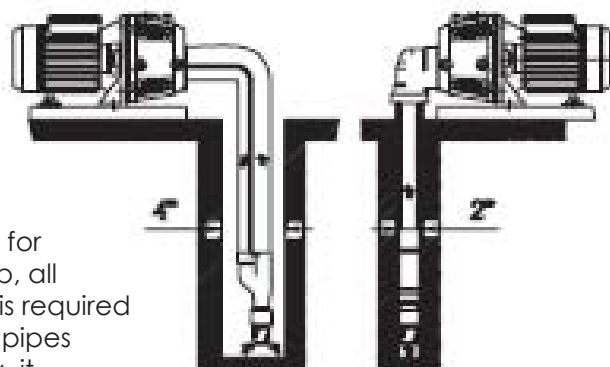

Application

Self-priming water pumps for suctions up to 45 metres deep. Suitable to pump water from wells and supply water pressure for domestic or industrial applications. Before installing the pump, all pipes must be free of leaks and obstructions. A check valve is required at the foot of the ejector. On installation fill completely both pipes and pump body with clean water. To ensure efficient priming, it is necessary to maintain a back pressure in the hydraulic circuit, it is recommended to install a membrane tank at the delivery of the pump together with a flow regulation valve.

Deep suction lifts are made possible by fitting the ejector in the well onto the end of the suction pipe. Recirculation of water passing through the Venturi creates a pocket of low pressure. This attracts water from around the ejector and pushes it through the return (suction) pipe with enough pressure to take it up to the surface. For these deep suction applications two pipes need to be connected: the delivery pipe to the ejector and the return (suction) outlet. In this case, the diameter of the well must be at least 100mm. If the pump has to go in a 2" well, a special ejector housing is required with an airtight lock on the well.

Operating conditions

- Max. working pressure 8 bar
- Liquid temperature up to 35°C
- Ambient temperature up to 40°C
- Maximum suction lift upto 45 mt.
- Continuous duty

Connections

- Suction 1 1/2" BSP
- Discharge 1" BSP

Motor and Materials

- Same as CA/CAM page 8



Technical Data GPS-AP/APM

TIPO - TYPE		POTENZA NOMINALE		POTENZA ASSORBITA	AMPERE				Q = PORTATA - CAPACITY																	
Monofase Single-phase	Trifase Three-phase	NOMINAL POWER		INPUT POWER	Monofase Single phase	Trifase Three phase	Tipo eiettore	Profon. aspiraz. m.	m ³ /h																	
		P2	P1	P1					0,18	0,36	0,6	0,9	1,2	1,5	1,8	2,1	3	3,6								
230V-50Hz	230/400V-50Hz	HP	kW	kW	1 x 230V	3 x 400V	Ejector	Suction depth m.	lt/1	3	6	10	15	20	25	30	35	50	60							
APM 150	AP 150	1,5	1,1	1,5	7	3	P 20	15									42	35	25	21						
								20										50	37	30	21					
								25													45	34	27			
								35												49	41	20				
								40																		
APM 200	AP 200	2	1,5	2	9,3	4,2	P 20	15										46	35	30						
								20												48	43	32	27			
								25												50	44	40	28	23		
								35														28	20			
								40												46	30					
							P 30	50																		

Stainless steel multi-stage pump GPS-SM

Application

Centrifugal self-priming multi-stage water pump able to deliver high pressure and a high suction lift with a comparatively low power consumption. Universal pump for domestic and industrial purposes.

Suitable for use as a domestic pressure system using either pressure tank system or electronic flow control systems to automatically switch the pump on and off.

Operating conditions

- Max. working pressure 8 bar
- Liquid temperature up to 35°C
- Ambient temperature up to 40°C
- Total suction lift up to 8 mt.
- Continuous duty

Motor

- Two pole induction motor 2850rpm
- Insulation class F
- Protection IP44

Materials

- Pump body - stainless steel
- Motor support - aluminium
- Impeller - noryl
- Diffuser - noryl
- Pump flange - stainless steel
- Shaft with rotor - stainless steel
- Mechanical seal - carbon/ceramic

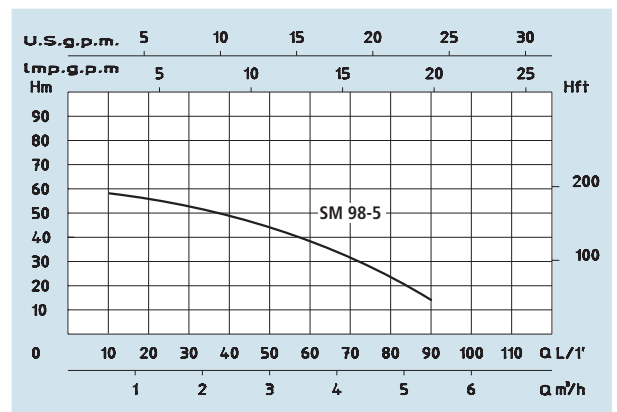
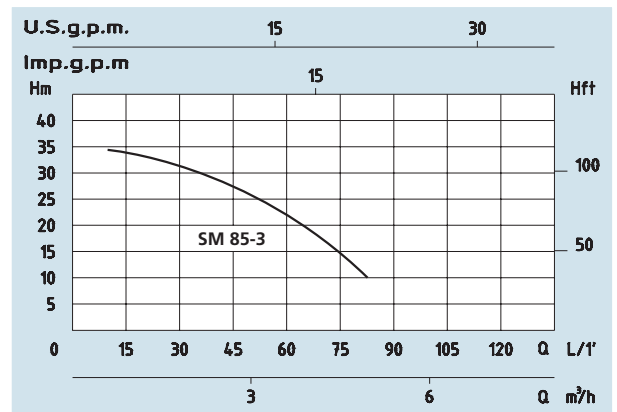

Technical data GPS-SM

TIPO - TYPE	POTENZA NOMINALE NOMINAL POWER P2		POTENZA ASSORBITA INPUT POWER P1	AMPERE	Q = PORTATA - CAPACITY										
	HP	kW	kW		Prevalenza manometrica totale in m.C.A. - Total head in meters w.c.										
Monofase Single-phase				Monofase Single-phase	m³/h	0,6	1,2	1,8	2,4	3	3,6	4,2	4,8	5,4	6
230V-50Hz				1 x 230V	lt/1'	10	20	30	40	50	60	70	80	90	100
SM 85-3	0,9	0,7	0,9	4	H (m)	34	32	30	28	24	20	15	10		
SM 98-5	1,3	1	1,3	5,8		58	56	52	48	44	39	31	23	15	

Multi-stage centrifugal pump GPS-RS/RSM



Application

Centrifugal horizontal multi-impeller water pumps able to develop high pressure and a high water lift with a comparatively low power consumption.

Suitable in domestic situations, for electronic pump control systems and for sprinkler irrigation systems and car washing.

Operating conditions

- Max. working pressure 10 bar
- Liquid temperature up to 35°C
- Ambient temperature up to 40°C
- Total suction lift up to 7m.
- Continuous duty

Motor

- Two-pole induction motor 2850 rpm
- Insulation class F
- Protection class IP44

Materials

- Pump body - cast iron
- Motor support - cast iron
- Impeller - noryl
- Diffusers - noryl
- Pump casing - stainless steel
- Shaft with rotor - stainless steel
- Mechanical seal - carbon/ceramic
- Mechanical seal - silicon/silicon (RS-RSM 40-50-60-80)

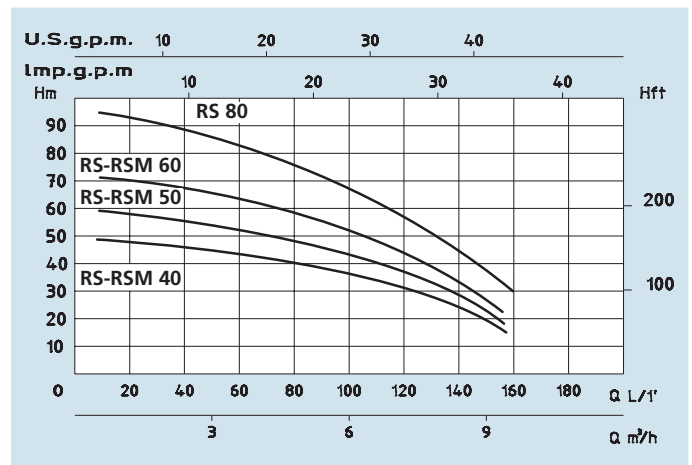
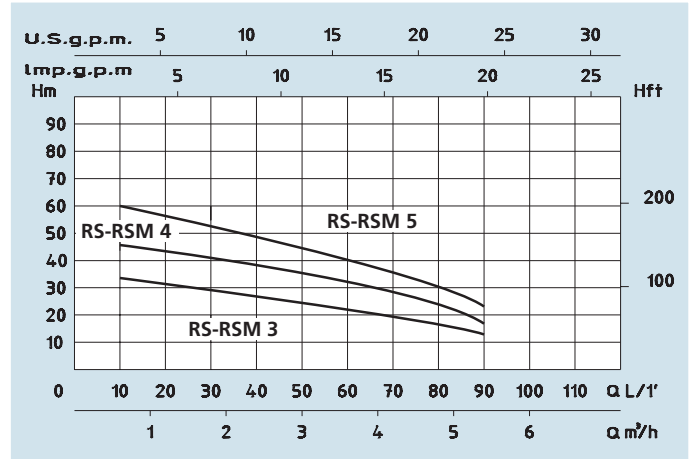

Technical Data GPS-RS/RSM

TIPO - TYPE		POTENZA NOMINALE NOMINAL POWER P2		POTENZA ASSORBITA INPUT POWER P1	AMPERE		Q = PORTATA - CAPACITY											
Monofase Single-phase	Trifase Three-phase	HP	kW	kW	Monofase Single-phase	Trifase Three-phase	m³/h	0,6	1,2	1,8	2,7	3,6	4,5	5,4	7,2	8,4	9,6	
230V-50Hz	230/400V-50Hz				1 x 230V	3 x 400V	lt/1	10	20	30	45	60	75	90	120	140	160	
RSM 3	RS 3	0,8	0,6	0,8	3,5	1,8	H (m)	34	33	31	28	23	18	13				
RSM 4	RS 4	1	0,7	1	4,8	2,2		45	44	43	38	33	25	18				
RSM 5	RS 5	1,5	1,1	1,4	6,2	3		60	56	53	47	40	33	24				
RSM 40	RS 40	2	1,5	2	9,3	4,2		49	48	47	44	43	40	37	30	23	15	
RSM 50	RS 50	2,5	1,9	2,2	10	4,6		59	57	56	55	52	48	44	34	25	18	
RSM 60	RS 60	3	2,2	2,7	12	5,3		71	68	67	65	64	58	53	41	32	22	
	RS 80	4	3	3,5		6,6		95	92	90	88	83	78	73	58	46	30	

Prevalenza manometrica totale in m.C.A. - Total head in meters w.c.

High head single impeller pump GPS-C/CM

Application

Single impeller centrifugal pumps suitable to cover any small, medium or large capacity request. Suitable for domestic, agricultural and industrial purposes; with automatic water distribution through small- and medium-sized tanks; for sprinkler and flood irrigation systems in gardening and agriculture; to increase in derivation system pressure in aqueducts.

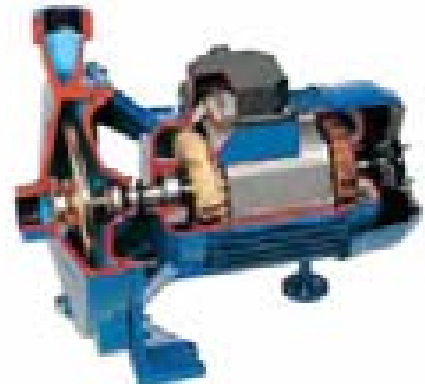

Operating conditions

- Max. working pressure 6Bar (C/CM22-27-32-35)
- Max. working pressure 8 bar (C/CM45-53-400-550)
- Liquid temperature up to 60°C
- Ambient temperature up to 40°C
- Total suction lift up to 7m
- Continuous duty

Motor

- Two pole induction motor (2850 rpm)
- Insulation class F
- Protection IP44

Materials

- Pump body cast iron
- Motor support cast iron (C-CM35-45-53-400-550)
- Motor support aluminium (C-CM22-27-32)
- Impeller noryl (C-CM22-27-32)

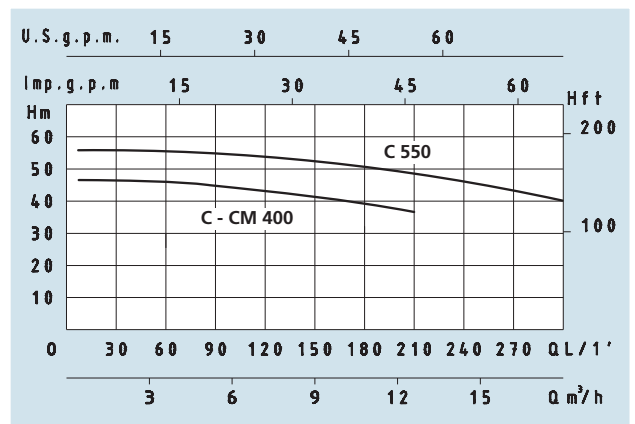
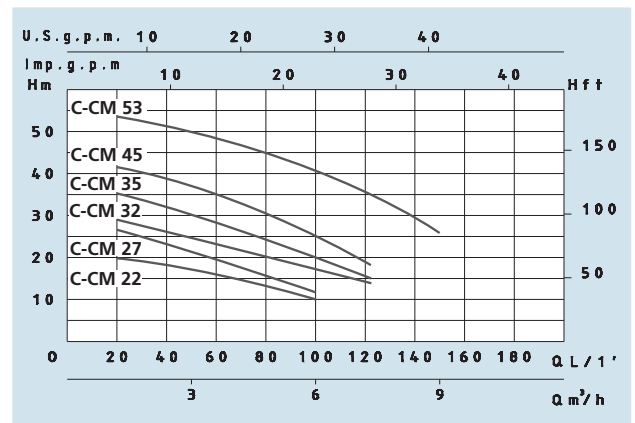

Technical data GPS-C/CM

TIPO - TYPE		POTENZA NOMINALE		POTENZA ASSORBITA	AMPERE		Q = PORTATA - CAPACITY											
Monofase Single-phase	Trifase Three-phase	NOMINAL POWER P2		INPUT POWER P1	Monofase Single-phase	Trifase Three-phase	m³/h	0,6	1,2	2,7	3,6	5,4	6	7,5	9	12	18	
		HP	kW															kW
230V-50Hz	230/400V-50Hz				1 x 230V	3 x 400V	Prevalenza manometrica totale in m.C.A. - Total head in meters w.c.											
CM 22	C 22	0,5	0,37	0,65	2,8	1,2	H (m)	20	18	17	16	12	10					
CM 27	C 27	0,75	0,55	0,9	4	1,7		27	25	20	18	14	12					
CM 32	C 32	1	0,75	1,2	5,5	2,3		29	28	26	23	20	18	14				
CM 35	C 35	1,5	1,1	1,6	7,5	3,1		36	33	30	28	24	22	15				
CM 45	C 45	2	1,5	2	9,3	4,2		43	42	37	35	27	25	18				
CM 53	C 53	3	2,2	3,3	14,5	5,9		54	53	50	48	45	42	36	26			
CM 400	C 400	4	3	4,6	21	7,6		47	46	45	44	43,5	43	42	41	38		
	C 550	5,5	4	5,2		9,6		57	56	55,5	55	54,5	54	53	52	50	40	

High head twin impeller pump GPS-2C/2CM

Application

Twin impeller centrifugal water pumps to lift clean water and non-aggressive liquids. The main feature are the two opposite impellers which allow higher lifts than in the single-impeller model.

They are suitable for civil and industrial installations for water distribution by tank pressure groups and for irrigation in gardening and agriculture.

Operating conditions

- Max. working pressure 6 bar (2C-2CM 42)
- Max. working pressure 10 bar (2C52-62-72-82-92-102-112-122)
- Max. liquid temperature 35°C (2C-2CM 42)
- Max. liquid temp. 60°C (2C52-62-72-82-92-102-112-122)
- Ambient temperature up to 40°C

Motors

- Two pole induction motor (2850 rpm)
- Insulation class F
- Protection IP 44

Material

- Pump body - cast iron
- Motor support - cast iron
- Impeller - brass
- Shaft with rotor - stainless steel
- Mechanical seal - carbon/ceramic

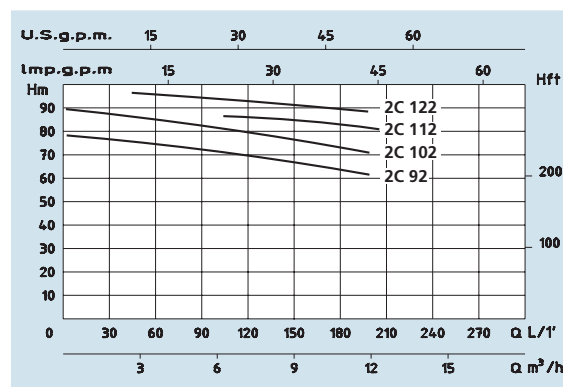
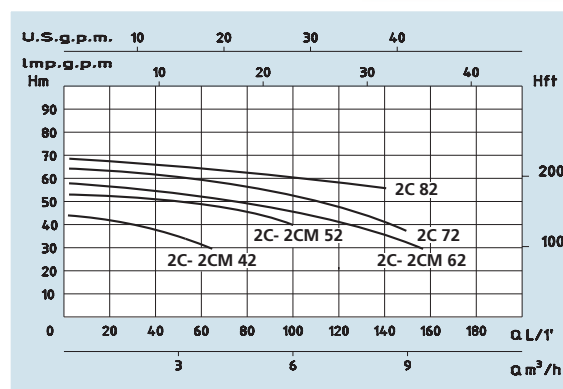

Technical data GPS-2C/2CM

TIPO - TYPE		POTENZA NOMINALE / POTENZA ASSORBITA			AMPERE		Q = PORTATA - CAPACITY											
Monofase Single-phase	Trifase Three-phase	NOMINAL POWER P2		INPUT POWER P1	Monofase Single-phase	Trifase Three-phase	m³/h	0	1,5	3	6	9	12	15	18	24	30	
		HP	kW				kW	lt/1	0	25	50	100	150	200	250	300	400	500
230V-50Hz	230/400V-50Hz				1 x 230V	3 x 400V	Prevalenza manometrica totale in m.C.A. - Total head in meters w.c.											
2CM42	2C42	1	0,75	1,25	5,5	2,5	H (m)	44	41	37								
2CM52	2C52	1,5	1,1	2,3	10,2	4,1		53	51	49	40							
2CM62	2C62	2	1,5	2,6	11,5	4,8		58	56	54	44	32						
	2C72	3	2,2	2,8		5,2		64	62	60	50	37						
	2C82	4	3	4,6		7,6		67	64	63	58,5	52	44					
	2C92	5,5	4	5,6		9,5		78,5	77	76	72	66	59					
	2C102	7,5	5,5	7,2		14,7		90	89	88,5	85	79	72,5	63				
	2C112	10	7,5	9,6		17,2		87	86	85,5	85	83	81	77,5	75	65	51	
	2C122	12,5	9,2	10,4		18,9		93,5	93	92,5	91	90	86	83	80	70	55	

Low head - medium flow pump GPS-CB/CBM

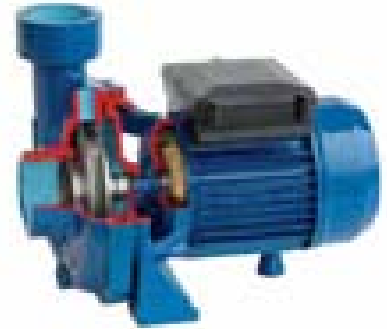

Application

Centrifugal single-impeller low-head water pumps for high flow rate irrigation and heat transfer systems. Suitable to pump clean water or non-aggressive liquids charged with small particles.

Operating conditions

- Max. working pressure 6 bar
- Liquid temperature up to 60°C
- Ambient temperature up to 40°C
- Total suction lift up to 7m.
- Continuous duty

Motor

- Two pole induction motor (2850 rpm)
- Insulation class F
- Protection IP44

Materials

- Pump body - cast iron
- Motor support - cast iron
- Impeller - cast iron
- Impeller - Bronze (CB/CBM 150)
- Shaft with rotor - stainless steel
- Mechanical seal - carbon/ceramic

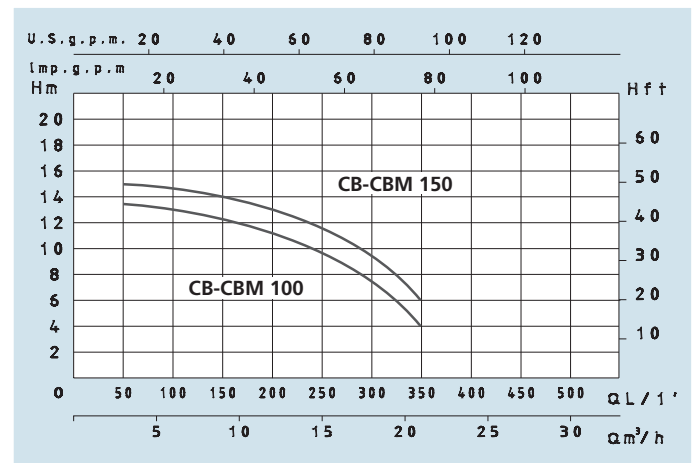
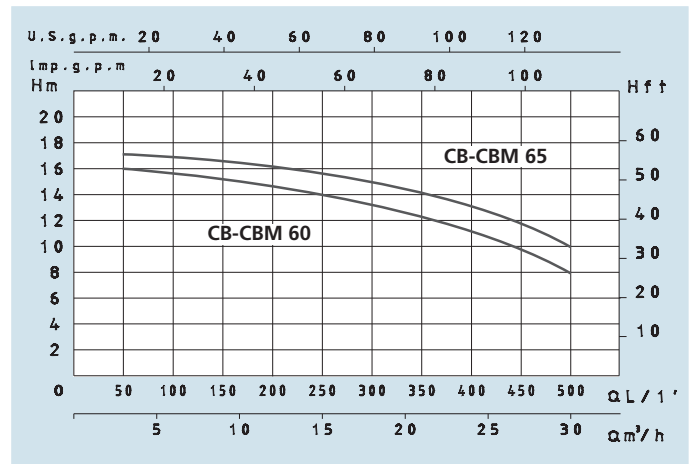

Technical data GPS-CB/CBM

TIPO - TYPE		POTENZA NOMINALE NOMINAL POWER P2		POTENZA ASSORBITA INPUT POWER P1	AMPERE		Q = PORTATA - CAPACITY											
Monofase Single-phase	Trifase Three-phase	HP	KW	KW	Monofase Single-phase	Trifase Three-phase	m³/h	3	6	9	12	15	18	21	24	27	30	
230V-50Hz	230/400V-50Hz				1 x 230V	3 x 400V	lt/1	50	100	150	200	250	300	350	400	450	500	
CBM 60	CB 60	1,5	1,1	1,9	7,5	3,1	Prevalenza manometrica totale in m.C.A. - Total head in meters w.c.											
CBM 65	CB 65	2	1,5	2,3	9,3	4,2	H (m)	16	15,7	15,3	15	14	13	12	11	10	8	
CBM 100	CB 100	1	0,75	1,1	5,3	2,2		17	16,8	16,7	16,5	15,8	15	14	13	12	10	
CBM 150	CB 150	1,5	1,1	1,8	6,8	3		13	12,8	12,2	11,5	10	7	4				
								15	14,8	14,3	13,8	13	9	6				

Low head - high flow pump GPS-CB/CBM



Application

Centrifugal single-impeller, low-head water pumps for high flow, low-head irrigation and transfer systems. Suitable to pump clean water or non-aggressive liquids charged with small particles.

Operating conditions

- Max. working pressure 6 bar
- Liquid temperature up to 60°C
- Ambient temperature up to 40°C
- Total suction lift up to 7 m
- Continuous duty

Motor

- Two-Pole induction motor (2850 rpm)
- Insulation class F
- Protection IP 44

Materials

- Pump body - cast iron
- Motor support - cast iron
- Impeller - cast iron
- Impeller - bronze (CB-CBM 152)
- Shaft with rotor stainless steel
- Mechanical seal carbon/ceramic

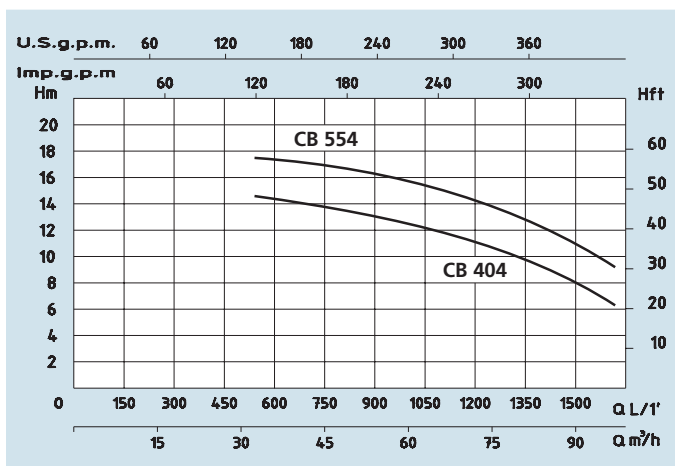
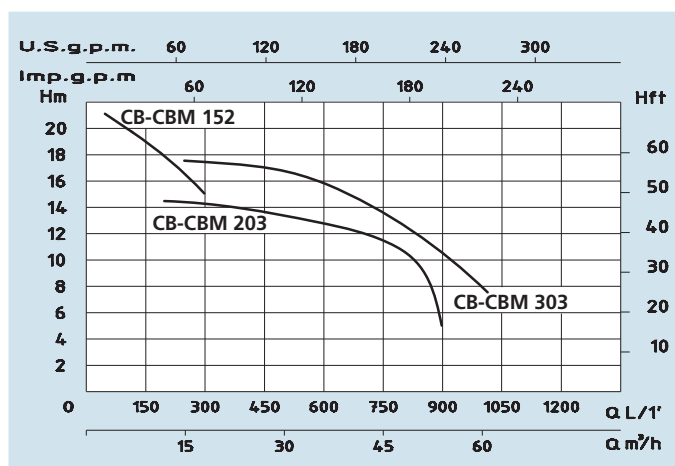

Technical data GPS-CB/CBM

TIPO - TYPE		POTENZA NOMINALE		POTENZA ASSORBITA	AMPERE		Q = PORTATA - CAPACITY												
Monofase Single-phase	Trifase Three-phase	NOMINAL POWER P2		INPUT POWER P1	Monofase Single-phase	Trifase Three-phase	Prevalenza manometrica totale in m.C.A. - Total head in meters w.c.												
		HP	kW				kW	m³/h	6	15	18	30	42	54	60	72	84	96	
230V-50Hz	230/400V-50Hz				1 x 230V	3 x 400V	lt/1	100	250	300	500	700	900	1000	1200	1400	1600		
CBM 152	CB 152	1,5	1,1	1,75	8,5	3,2	H (m)	21,5	17,5	15,3									
CBM 203	CB 203	2	1,5	2,2	11	3,6			14,2	14	12,8	12	4,8						
CBM 303	CB 303	3	2,2	3,3	15	4,9			17,5	17,4	16,4	14,2	10,2	7,5					
	CB 404	4	3	3,5		6,2					14,3	13,9	12,8	12,1	10,9	8,3	6,1		
	CB 554	5,5	4	5		8,8					17,5	17,1	16,3	15,7	14,4	12,2	10		

Standardised centrifugal pumps GPS-CS

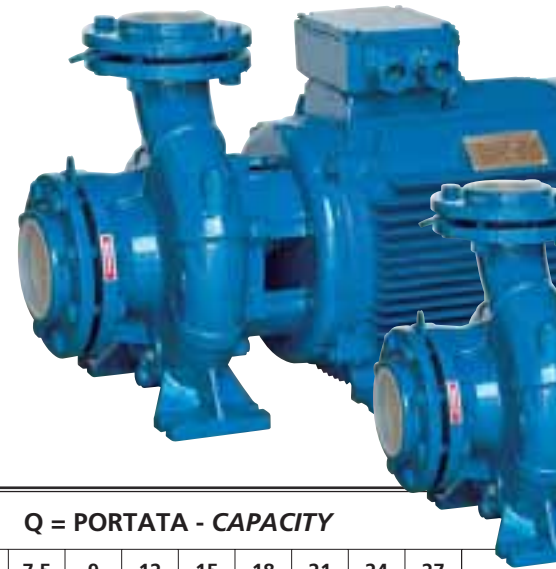

TIPO TYPE	POTENZA ASSORBITA	POTENZA NOMINALE		AMPERE	Q = PORTATA - CAPACITY									
	INPUT POWER P1	NOMINAL POWER P2		Trifase Three- phase	0	6	7,5	9	12	15	18	21	24	27
		kW	HP		kW	0	100	125	150	200	250	300	350	400
					3 x 400V	Prevalenza manometrica totale in m.C.A. - Total head in meters w.c.								
CS 32-160 C	2,5	2	1,5	4,8		25,5	25,3	25	24	23	21,5	20	18	15,5
CS 32-160 B	3	3	2,2	5,7		28,8	28,5	28	27	26	24,5	23	21,5	18,5
CS 32-160 A	4,3	4	3	7		36,5	36	35,5	34,5	33	31,5	30	28,5	26
CS 32-200 C	5,7	5,5	4	8,8		40,7	40,5	40	39,5	39	38	36,5	35	33
CS 32-200 B	8,6	7,5	5,5	14		55,7	55,5	55	54,5	54	53	51,5	50	48
CS 32-200 A	9,5	10	7,5	15		60,7	60,5	60	59,5	58,5	57	55,5	54	52
CS 32-250 C	11,5	12,5	9,2	18,5			70	69,5	68,5	67,5	66	64,5	62,5	59,5
CS 32-250 B	13,5	15	11	21,5			81	80,5	79,5	78,5	77	75,5	73,5	71
CS 32-250 A	15,5	20	15	25			90,5	90	89,5	89	87,5	86	84	81,5
CS 40-160 B	4,8	4	3	7,5				32,7	32,5	32,3	32	31,5	30,5	29,5
CS 40-160 A	5,7	5,5	4	8,8				36,2	36	35,8	35,5	35	34	33
CS 40-200 B	8,6	7,5	5,5	14				46,5	46	45,5	45	44,5	43,5	42,5
CS 40-200 A	11,3	10	7,5	18				56	55,5	55	54,5	54	53	52
CS 40-250 B	14,5	15	11	22,5				74	73,9	73,8	73,7	73,5	73	72
CS 40-250 A	18	20	15	29				91,5	91,4	91,3	91,2	91	90,5	90
CS 50-160 C	5,7	5,5	4	8,8								29,5	29,2	28,8
CS 50-160 B	8,2	7,5	5,5	13,2								37	36,8	36,5
CS 50-160 A	9,5	10	7,5	15								40	39,8	39,5
CS 50-200 C	11,5	12,5	9,2	18,5									48,7	48,5
CS 50-200 B	13	15	11	21									52,7	52,5
CS 50-200 A	17,5	20	15	28									64,5	64
CS 50-250 C	20	20	15	32										71,3
CS 50-250 B	23	25	18,5	36,5										80,8
CS 50-250 A	27	30	22,5	43										90
CS 65-160 D	10	10	7,5	16										
CS 65-160 C	11,5	12,5	9,2	18,5										
CS 65-160 B	13	15	11	21										
CS 65-160 A	16	20	15	26										
CS 65-200 C	20	20	15	32										
CS 65-200 B	23	25	18,5	36,5										
CS 65-200 A	27	30	22,5	43										
CS 80-160 D	12,5	15	11	20,5										
CS 80-160 C	15	20	15	24										
CS 80-160 B	18,5	25	18,5	30										
CS 80-160 A	22	30	22,5	35										
CS 80-200 B	33,5	40	30	54										
CS 80-200 A	39	50	37	62										

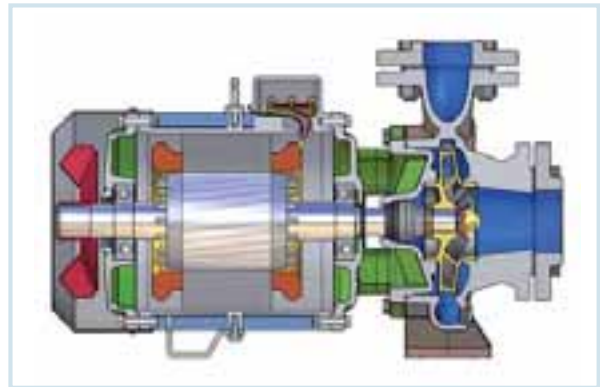
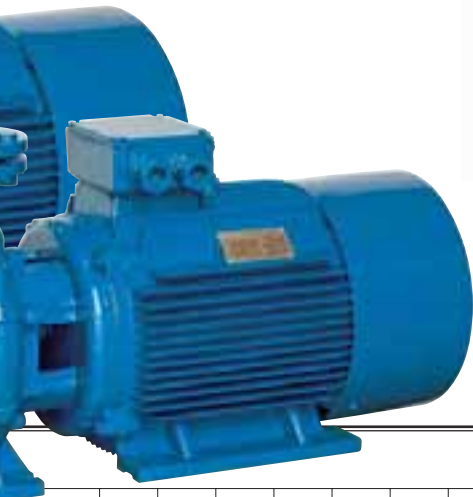

Q = PORTATA - CAPACITY

	30	33	36	39	42	48	54	60	66	72	78	84	96	108	120	132	144	156	168	180	195	210	225	240	
	500	550	600	650	700	800	900	1000	1100	1200	1300	1400	1600	1800	2000	2200	2400	2600	2800	3000	3250	3500	3750	4000	
<i>Prevalenza manometrica totale in m.C.A. - Total head in meters w.c.</i>																									
	15,5																								
	23,5																								
	31,5	29	26																						
	46,5	44,5	42,5																						
	49,5	47,5	45,5																						
	56	51	45																						
	67,5	63,5	58																						
	78	74	68,5																						
	28	27	25,5	23	21																				
	32	31	29,5	28	26	22																			
	41,5	40,5	39,5	38,5	37	34,5	31,5																		
	51	50	49	48	46,5	44	40,5	37																	
	71	70	68,5	67	65,5	61,5																			
	89	88	87	85,5	83,5	79,5																			
	28,3	27,8	27,1	26,4	25,6	24	22,5	20,5	18	15,5															
	36	35,5	35	34,5	34	32	30,5	28,5	26	23,5	20,5														
	39	38,5	38	37,5	37	35	33,5	31,5	29	26,5	23														
	48,2	47,8	47,5	47	46,5	45	43,5	42	39,5	37	33														
	52,2	51,7	51,2	50,7	50,2	49,2	48	46	43,5	41	38														
	63,5	63	62,5	62	61,5	60,5	59,5	58	56,5	54,5	51,5														
	71	70,5	70	69,5	68,5	67	65	63	61	58	54														
	80,5	80	79,5	79	78,5	77	75	73	70,5	68	65														
	89,7	89,3	89	88,5	88	86,5	85	83	81	79	71														
					28,5	28,2	28	27,5	27	26,5	25,8	25	23	21	18	14									
					32	31,7	31,5	31,2	30,7	30,2	29,7	29	27	25	22	19	16								
					35,5	35	34,8	34,5	34	33,5	33	32,5	31	29	26,5	24	20								
					40	39,5	39	38,5	38	37,5	37	36,5	35,5	33,5	31	28,5	26								
					48,5	48	47,5	47	46,2	45,5	44,5	42,5	40,5	38	34,5	31									
					52,5	52	51,5	51	50,5	50	49	47	45	43	40	36									
					60,5	60	59,5	59	58,5	58	57,5	56	54,5	52,5	49,5	45,5									
									27,5	27,4	27,3	27,1	26,4	25,2	24	22,5	21	19,2	17,4	15,5					
									30,6	30,5	30,4	30,2	29,6	28,7	27,5	26,2	24,8	23,2	21,5	19,6	17				
									35	34,9	34,8	34,6	34,1	33,4	32,5	31,3	30,2	28,7	27	25,3	22,8	20			
									38,6	38,5	38,2	38	37,7	37	36,3	35,3	34,2	33	31,6	30	27,8	25	22		
									54,1	54	53,8	53,6	53,1	52,2	51,3	50,4	49,2	47,7	46,2	44,2	41,2	38	33,6	28,5	
									58,8	58,7	58,5	58,3	57,8	57,2	56,3	55,4	54,2	53	51,5	50	48	45	42	39	

Standardised centrifugal pumps GPS-CS

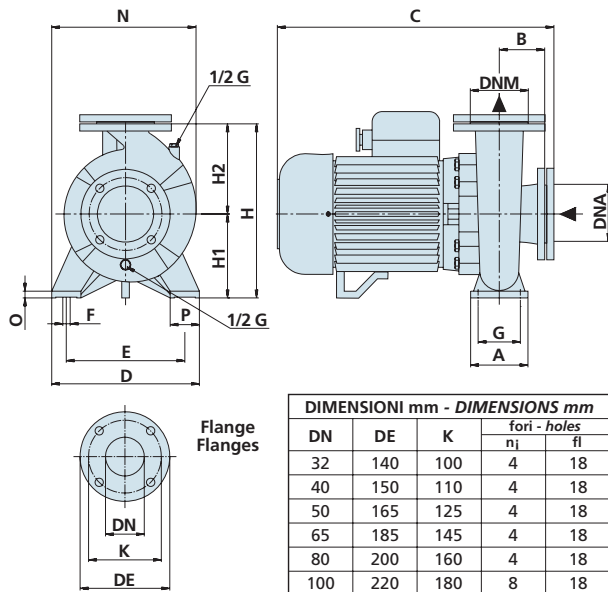

DIMENSIONI mm - DIMENSIONS mm				
DN	DE	K	fori - holes	
			n _i	fi
32	140	100	4	18
40	150	110	4	18
50	165	125	4	18
65	185	145	4	18
80	200	160	4	18
100	220	180	8	18

Operating conditions

- Max. working pressure 10 bar
- Liquid temperature up to 90°C
- Ambient temperature up to 40°C
- Total suction lift up to 7 mt.
- Continuous duty

Motor

- Two pole induction motor (2850rpm)
- Insulation class F
- Protection IP54
- IEC 34 construction standard

Materials

- Pump body - cast iron, dimensioned to DIN 24255
- Flange holes - UNI 7467, PN10 threaded flanges
- Pump body, motor support - cast iron;
- Impeller - cast iron;
- Shaft - stainless steel;
- Mechanical seal -

Dimensions and weights

TIPO TYPE	DIMENSIONI mm - DIMENSIONS mm															Dimensioni Dimensions mm			Peso Weight Kg
	A	B	C	D	E	F	G	H	H1	H2	N	O	P	DNA	DNM	P	L	H	
CS 32-160 C	100	80	480	240	190	15	70	322	132	160	240	13,5	50	50	32	250	520	360	36
CS 32-160 B	100	80	480	240	190	15	70	322	132	160	240	13,5	50	50	32	250	520	360	39
CS 32-160 A	100	80	510	240	190	15	70	322	132	160	240	13,5	50	50	32	250	520	360	42
CS 32-200 C	100	80	550	240	190	15	70	370	160	180	273	15	50	50	32	300	660	390	52
CS 32-200 B	100	80	630	240	190	15	70	370	160	180	273	15	50	50	32	300	660	390	63
CS 32-200 A	100	80	630	240	190	15	70	370	160	180	273	15	50	50	32	300	660	390	69
CS 32-250 C	125	100	745	320	250	15	95	445	180	225	335	18	65	50	32	355	790	455	83
CS 32-250 B	125	100	745	320	250	15	95	445	180	225	335	18	65	50	32	355	790	455	90
CS 32-250 A	125	100	745	320	250	15	95	445	180	225	335	18	65	50	32	355	790	455	120
CS 40-160 B	100	80	550	240	190	15	70	322	132	160	240	15	50	65	40	250	560	370	47
CS 40-160 A	100	80	550	240	190	15	70	322	132	160	240	15	50	65	40	250	560	370	50
CS 40-200 B	100	100	640	265	212	15	70	370	160	180	281	15	50	65	40	300	660	390	65
CS 40-200 A	100	100	640	265	212	15	70	370	160	180	281	15	50	65	40	300	660	390	71
CS 40-250 B	125	100	745	320	250	15	95	435	180	225	335	18	65	65	40	355	790	455	91
CS 40-250 A	125	100	745	320	250	15	95	435	180	225	335	18	65	65	40	355	790	455	121
CS 50-160 C	100	100	575	265	212	15	70	372	160	180	268	15	50	65	50	300	660	390	60
CS 50-160 B	100	100	650	265	212	15	70	372	160	180	268	15	50	65	50	300	660	390	65
CS 50-160 A	100	100	650	265	212	15	70	372	160	180	268	15	50	65	50	300	660	390	71
CS 50-200 C	100	100	745	265	212	15	70	425	160	200	335	18	50	65	50	355	790	455	82
CS 50-200 B	100	100	745	265	212	15	70	425	160	200	335	18	50	65	50	355	790	455	89
CS 50-200 A	100	100	745	265	212	15	70	425	160	200	335	18	50	65	50	355	790	455	122
CS 50-250 C	125	100	750	320	250	15	95	435	180	225	340	18	65	65	50	355	790	455	125
CS 50-250 B	125	100	795	320	250	15	95	435	180	225	340	18	65	65	50	355	790	455	140
CS 50-250 A	125	100	825	320	250	15	95	455	180	225	360	18	65	65	50	380	850	465	149
CS 65-160 D	125	100	650	280	212	15	95	425	160	200	340	18	65	80	65	355	790	455	80
CS 65-160 C	125	100	750	280	212	15	95	425	160	200	340	18	65	80	65	355	790	455	84
CS 65-160 B	125	100	750	280	212	15	95	425	160	200	340	18	65	80	65	355	790	455	90
CS 65-160 A	125	100	750	280	212	15	95	425	160	200	340	18	65	80	65	355	790	455	120
CS 65-200 C	125	100	745	320	250	15	95	445	180	225	335	18	65	80	65	355	790	455	122
CS 65-200 B	125	100	790	320	250	15	95	445	180	225	335	18	65	80	65	355	790	455	138
CS 65-200 A	125	100	825	320	250	15	95	455	180	225	360	18	65	80	65	380	850	465	148
CS 80-160 D	125	125	790	320	250	15	95	445	180	225	350	18	65	100	80	380	850	465	99
CS 80-160 C	125	125	790	320	250	15	95	445	180	225	350	18	65	100	80	380	850	465	129
CS 80-160 B	125	125	835	320	250	15	95	445	180	225	350	18	65	100	80	380	850	465	143
CS 80-160 A	125	125	870	320	250	15	95	445	180	225	360	18	65	100	80	380	920	485	152
CS 80-200 B	125	125	900	345	280	15	95	470	180	225	360	18	65	100	80	380	920	485	233
CS 80-200 A	125	125	900	345	280	15	95	470	180	225	360	18	65	100	80	380	920	485	247

Standardised centrifugal pump GPS-CS32

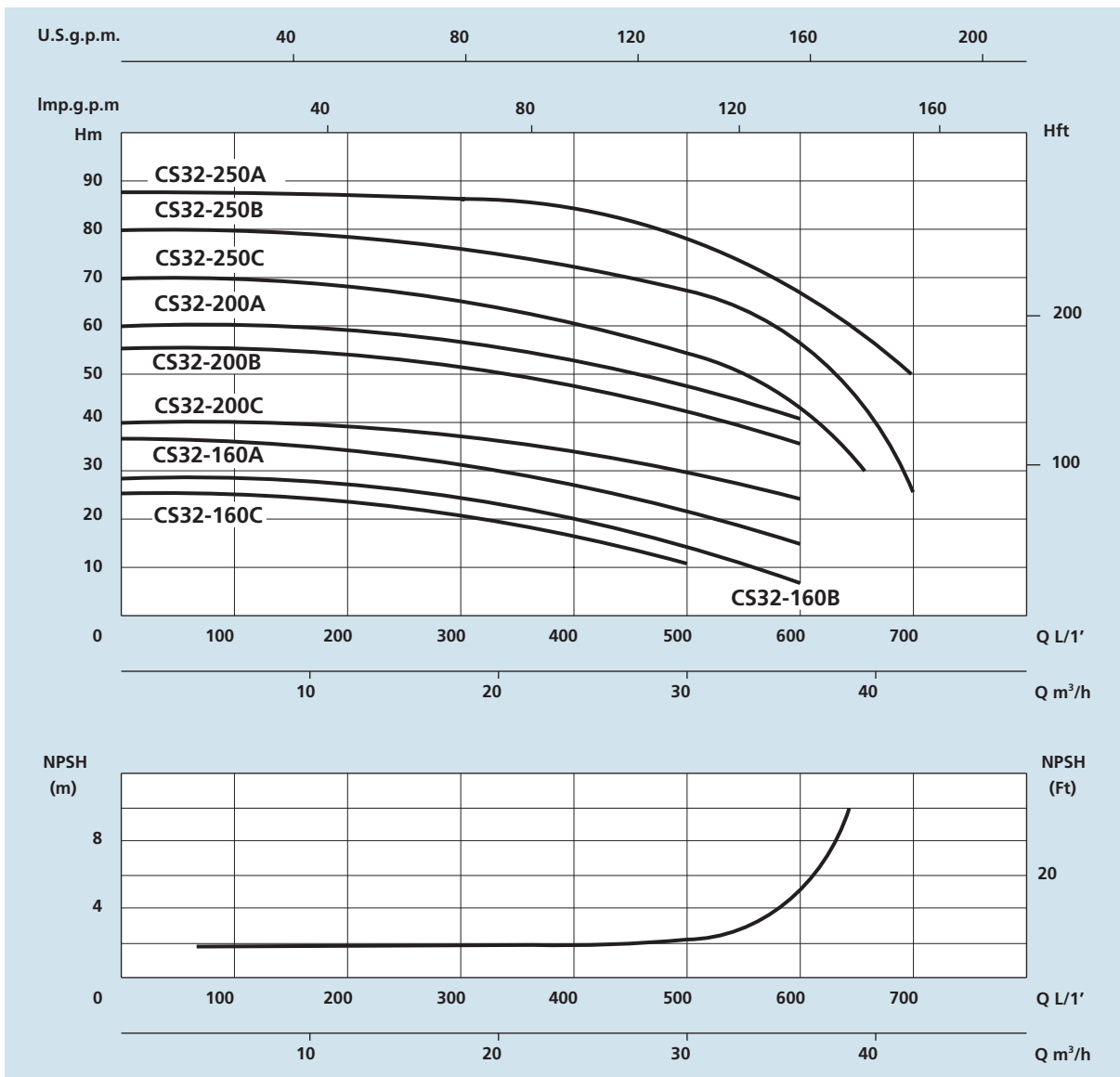
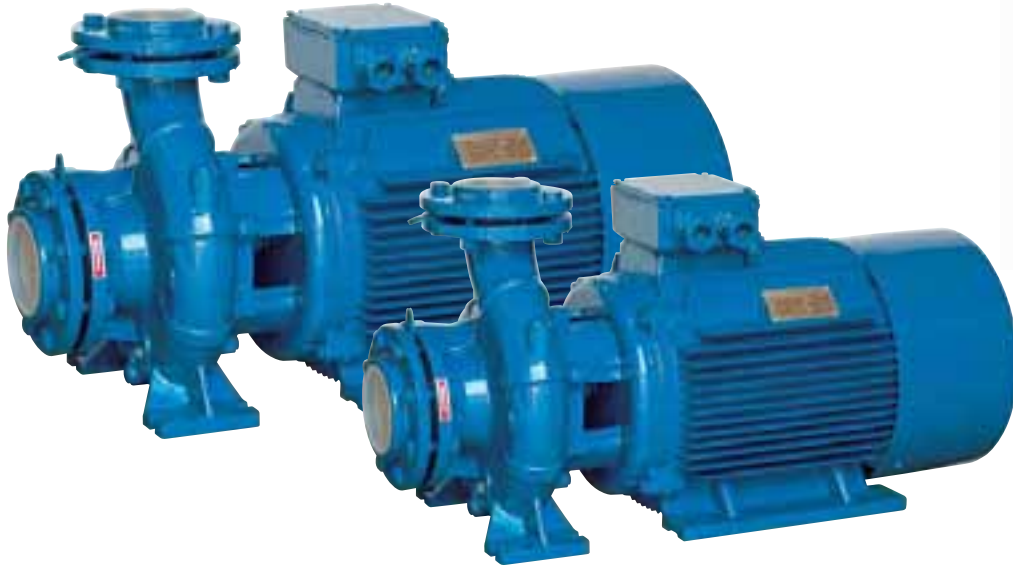

Standardised centrifugal pumps GPS-CS40

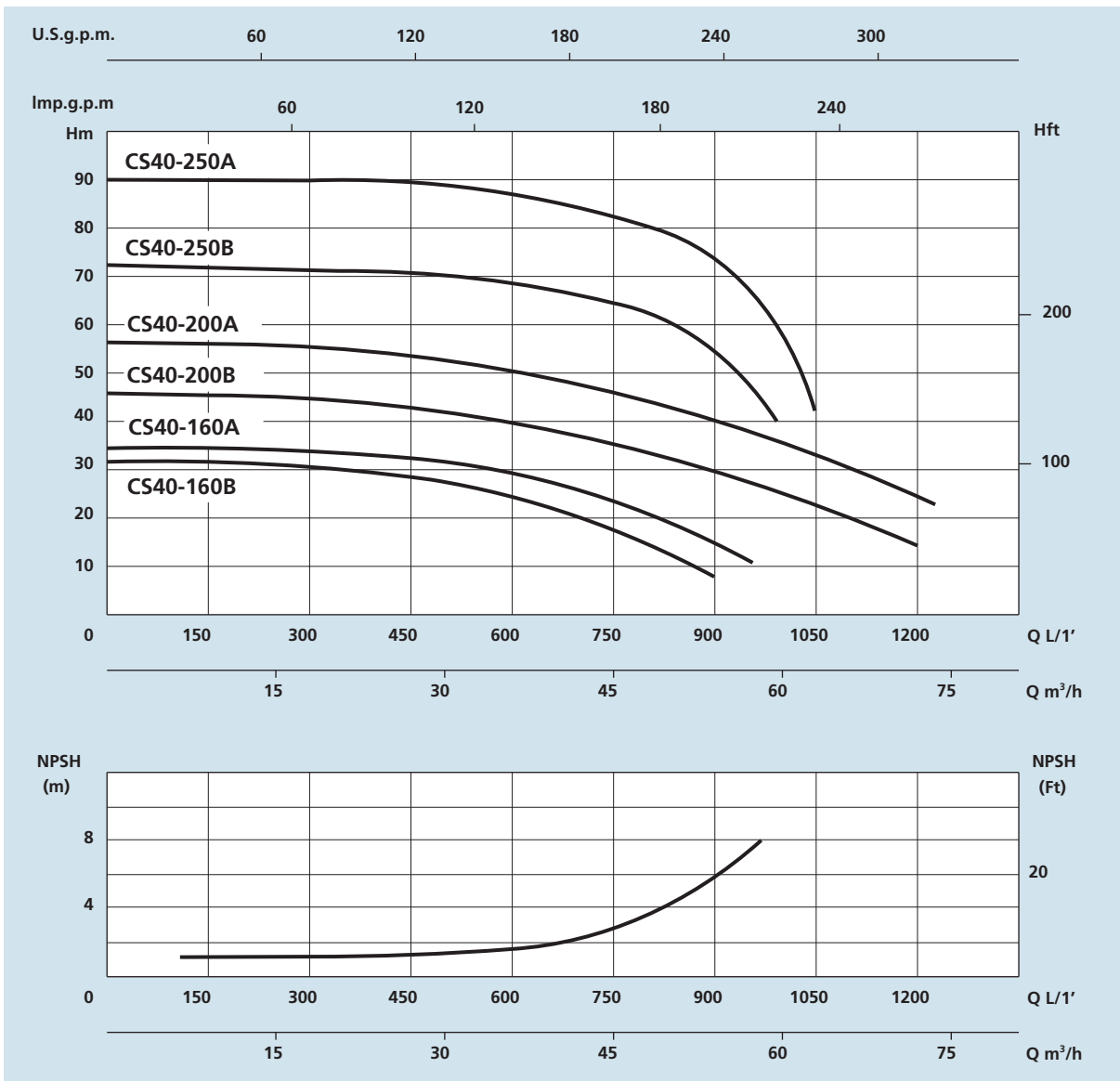
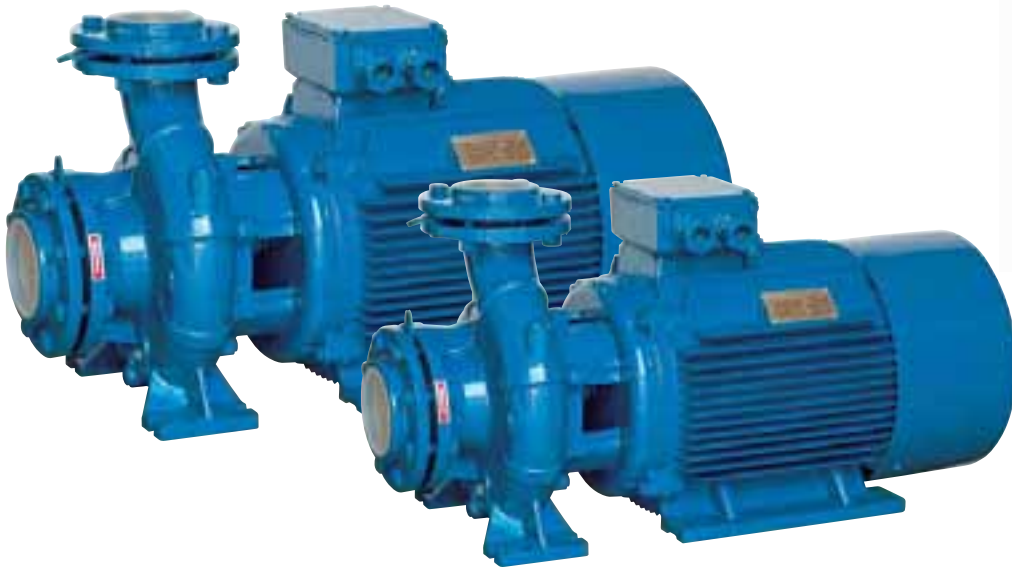

Standardised centrifugal pumps GPS-CS50

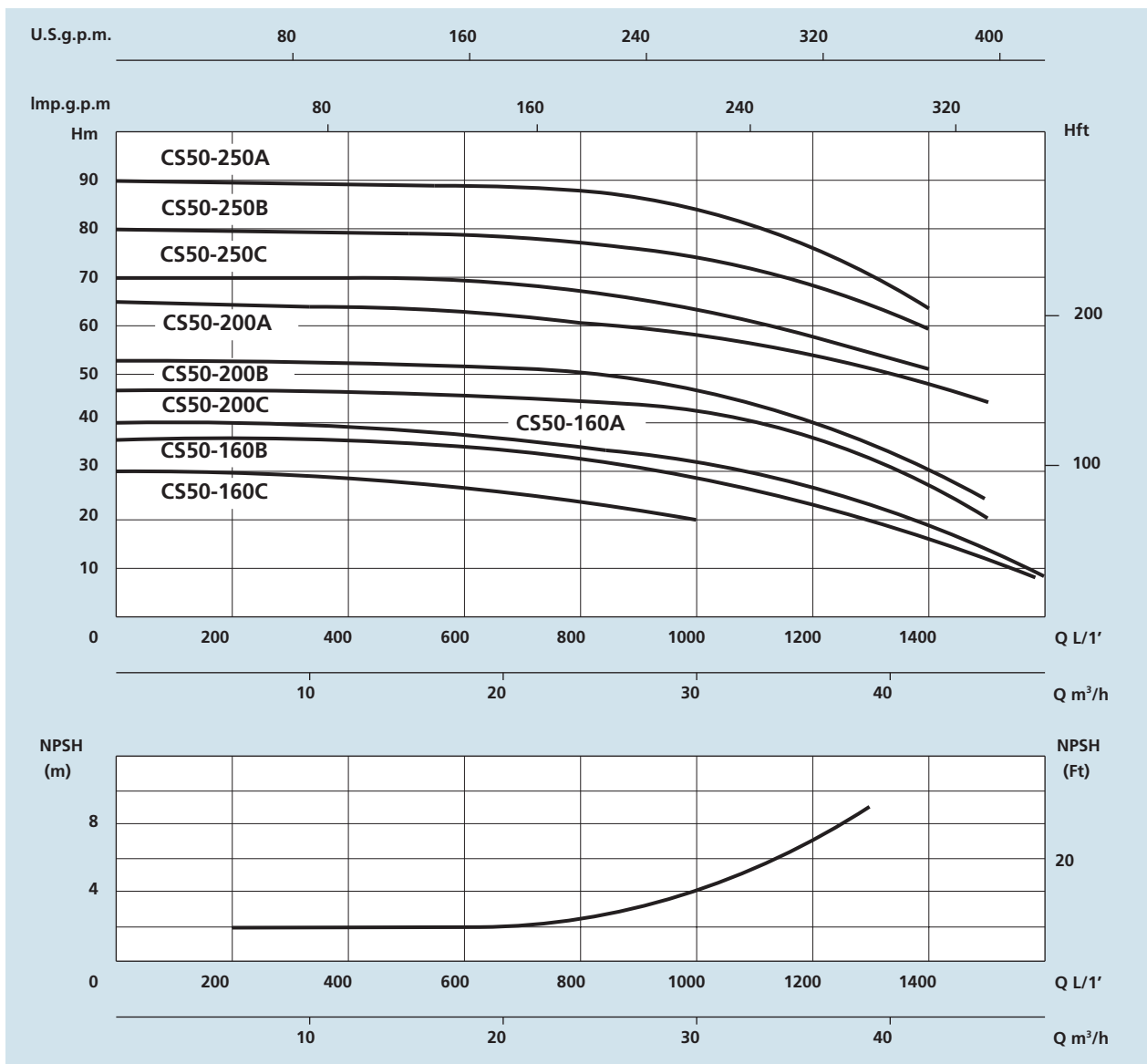
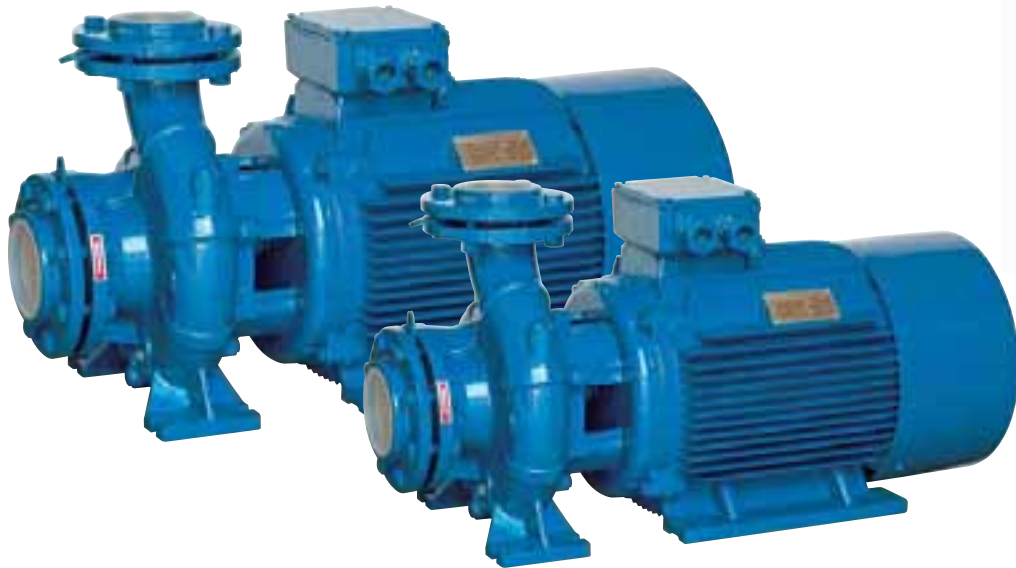

Standardised centrifugal pumps GPS-CS65

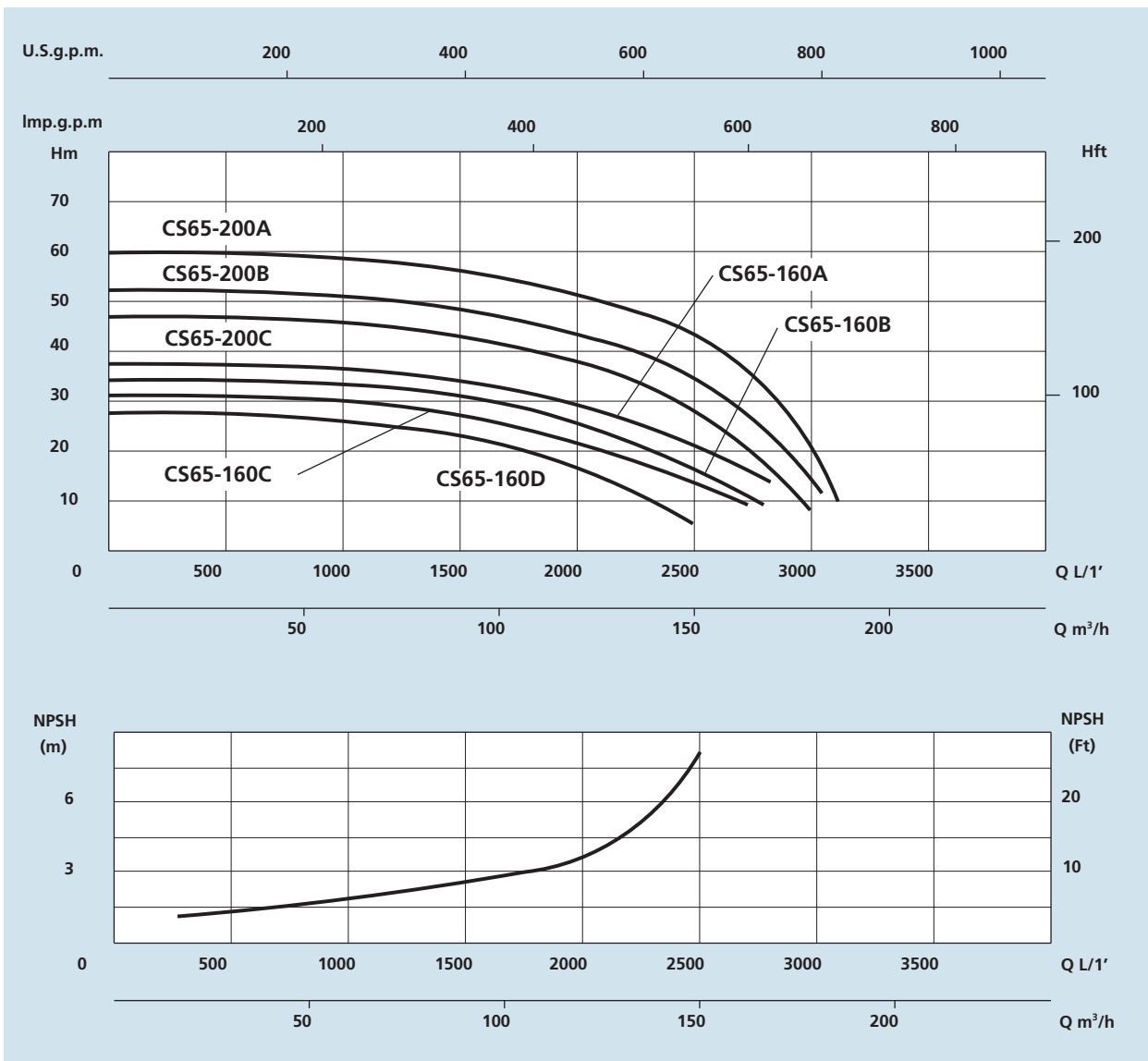
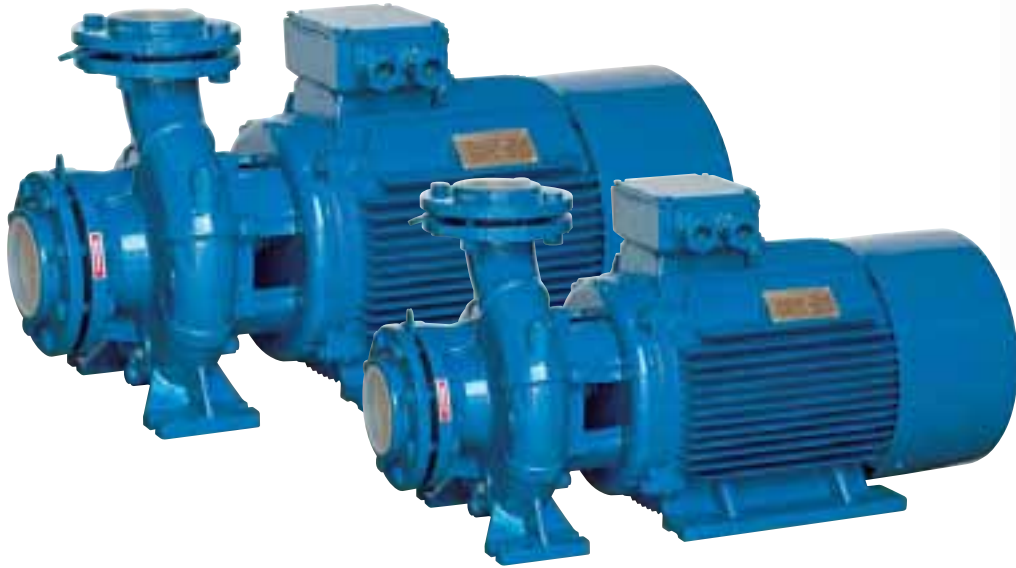

Standardised centrifugal pumps GPS-CS80

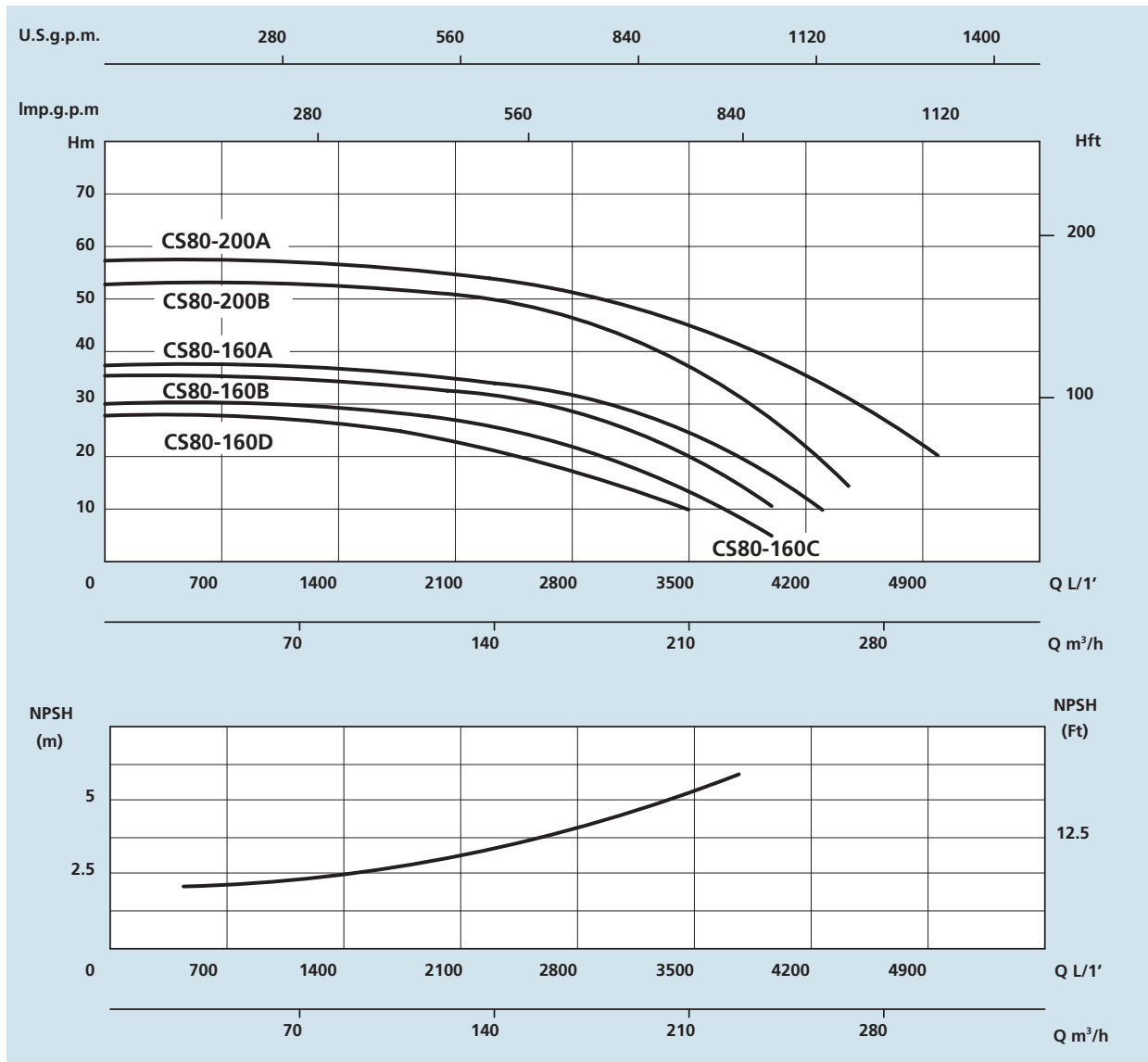
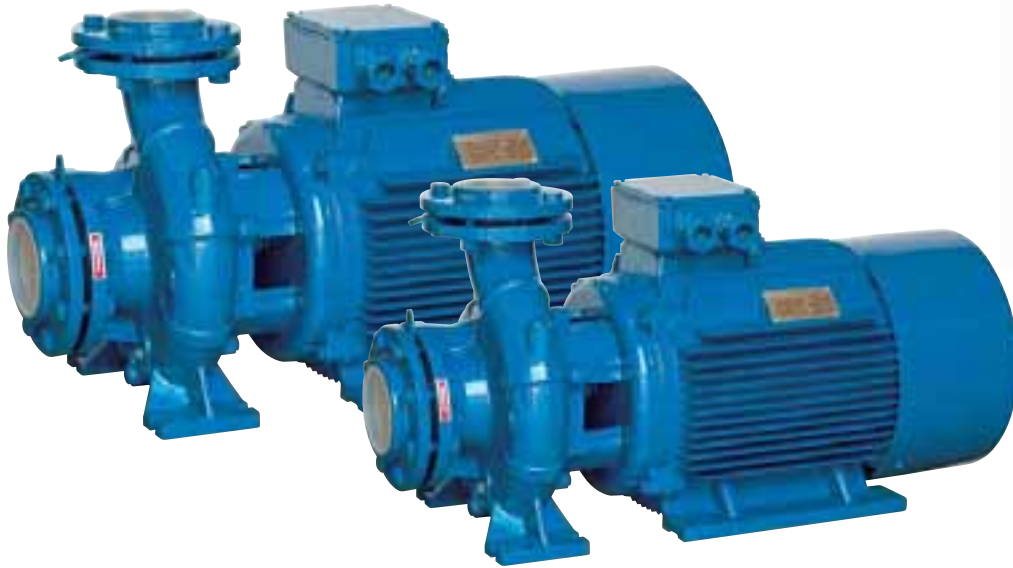

Pool pump GPS-MPC/MPCM

Application

For water circulation in swimming pool filtration systems. Suitable for pumping clean or slightly dirty water with solid particles in suspension.

Operating conditions

- Water temperature up to 60°C
- Ambient Temperature up to 40°C
- Max. working pressure 250kPa

Construction

Self-priming swimming pool pump with built-in strainer. The motor is specially insulated from the pumped water. Materials have been chosen for resistance to corrosion and wear from sand.

Motor

- Built-in overload motor protector with automatic reset 230 volt model
- Permanent split capacitor (PSC)
- Insulation class F
- Protection IP x4

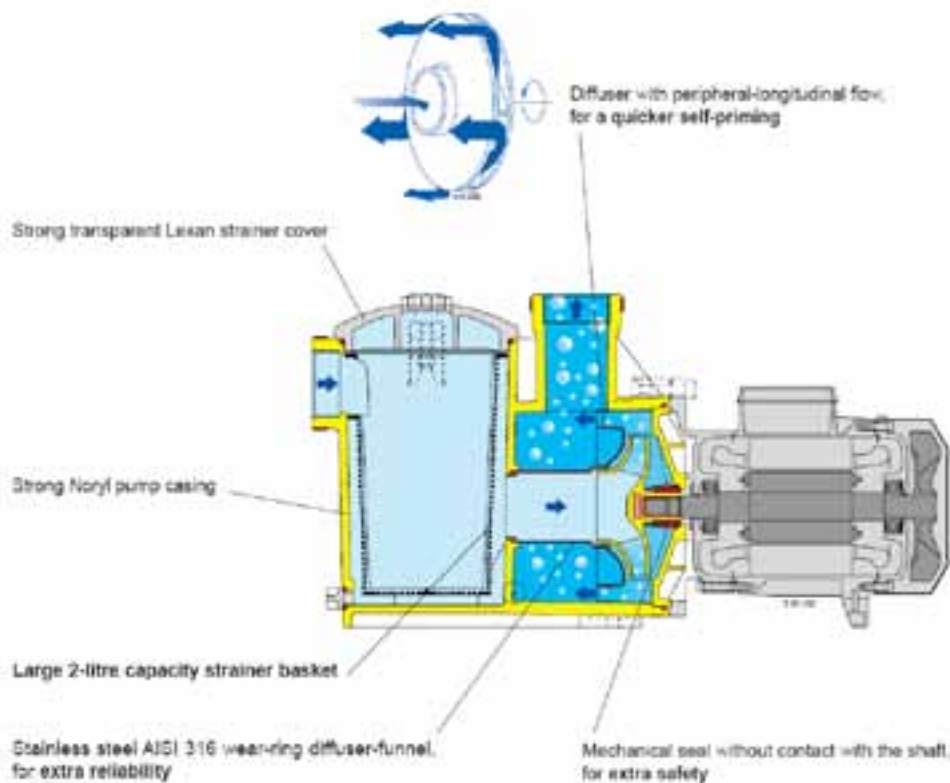

Pool pump GPS-MPC/MPCM

Technical data GPS-MPC/MPCM

	3~ 230 V 400 V		1~ 230 V P ₁		P ₂		Q	H								
	A	A	A	kW	kW	HP		m ³ /h	0	3	6	9	12	15	18	21
MPC 1E	2.8	1.6	MPCM 1E	3.3	0.73	0.37	0.5	0	50	100	150	200	250	300	350	
MPC 2E	3	1.7	MPCM 2E	4.5	1	0.55	0.75	0	50	100	150	200	250	300	350	
MPC 3E	3.7	2.2	MPCM 3E	5.4	1.2	0.75	1	0	50	100	150	200	250	300	350	
MPC 4E	5	2.9	MPCM 4E	7	1.5	1.1	1.5	0	50	100	150	200	250	300	350	

	3~ 230 V 400 V		1~ 230 V P ₁		P ₂		Q	H										
	A	A	A	kW	kW	HP		m ³ /h	0	3	9	15	18	21	24	27	30	34
MPC 5	3	2.9	MPCM 5	7	1.5	1.1	1.5	0	50	150	250	300	350	400	450	500	567	657
MPC 6	6.4	3.7	MPCM 6	9.2	2	1.5	2	0	50	150	250	300	350	400	450	500	567	657
MPC 7	9.15	5.3	MPCM 7	14	3	2.2	3	0	50	150	250	300	350	400	450	500	567	657

P₁ Max. power input.

P₂ Rated motor power output.

H Total head in m.

Tolerances according to ISO 9905, annex A.

Self-Priming Capability with the pump located above the water level

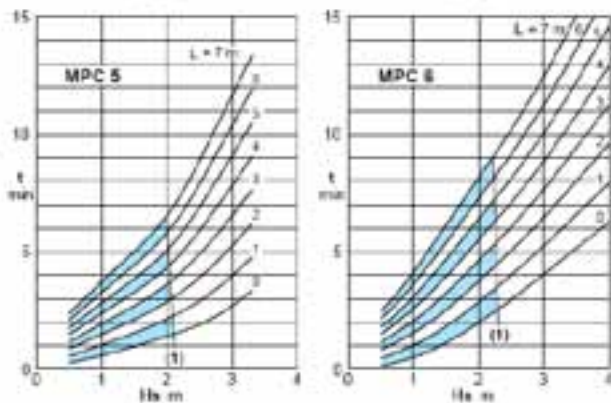
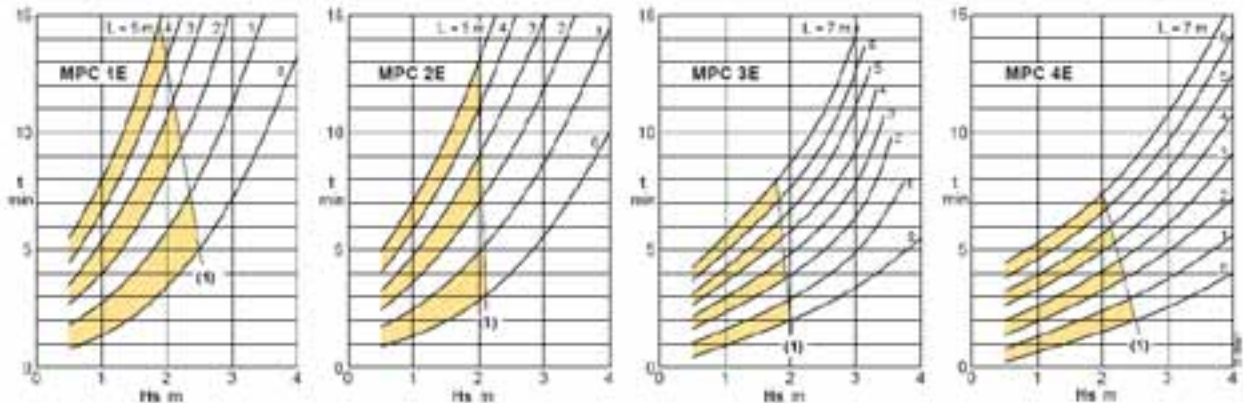

(1) Application limit for automatic self-priming at each start-up, without check valve.

L (m) Horizontal length of suction pipe above the water level.

H_s (m) Suction lift.

t (min) Self-priming time.

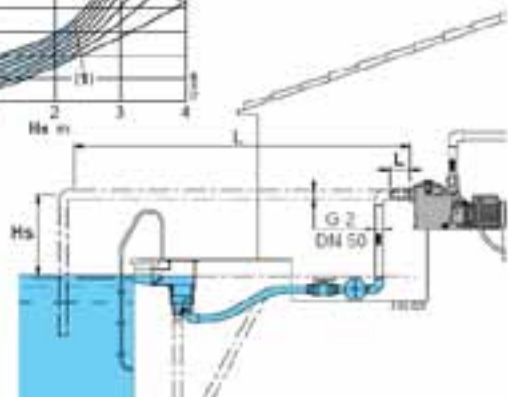

Spa Pump GPS-SPA/SPAM



Construction

Self-draining, single-impeller pumps, with motor insulated from pumped water, constructed with high quality, corrosion-proof plastic materials, with stainless steel diffuser. Compact design (158 mm wide).

PVC pipe connections:

Parts for cementing joint, with external thread for union coupling.

Applications

For spas, hydromassage bathtubs and whirlpool baths.

Operating Characteristics

Water temperature up to 60 °C.

Room temperature up to 40 °C.

Maximum permissible pressure in the pump casing: 2,5 bar.
Continuous duty.

Motor

2-pole induction motor, 50 Hz (n = 2800 1/min).

SPA: three-phase 230/400 V ± 10%.

SPAM: single-phase 230 V ± 10%, with thermal protector. Capacitor inside the terminal box.

Insulation class F.

Protection IP X5.

Constructed in accordance with: EN 60335-2-41 IEC 60335-2-41
EN 60335-2-60 IEC 60335-2-60.

Materials

Component	Material
Pump casing Union coupling	ABS (Acrylonitrile-Butadiene-Styrene)
Diffuser cover Impeller	Glass reinforced thermoplastic: PPO-GF30, NORYL*
Diffuser-wall with wear-ring	Cr-Ni-Mo stainless steel 1.4401 EN 10088 (AISI 316)
Mechanical seal	Ceramic alumina, Carbon, FPM

* Trademark of General Electric

Patents:

EP 0 460 597
US 5 226 790

Certification marks for SPAM



Coverage chart n = 2800 rpm

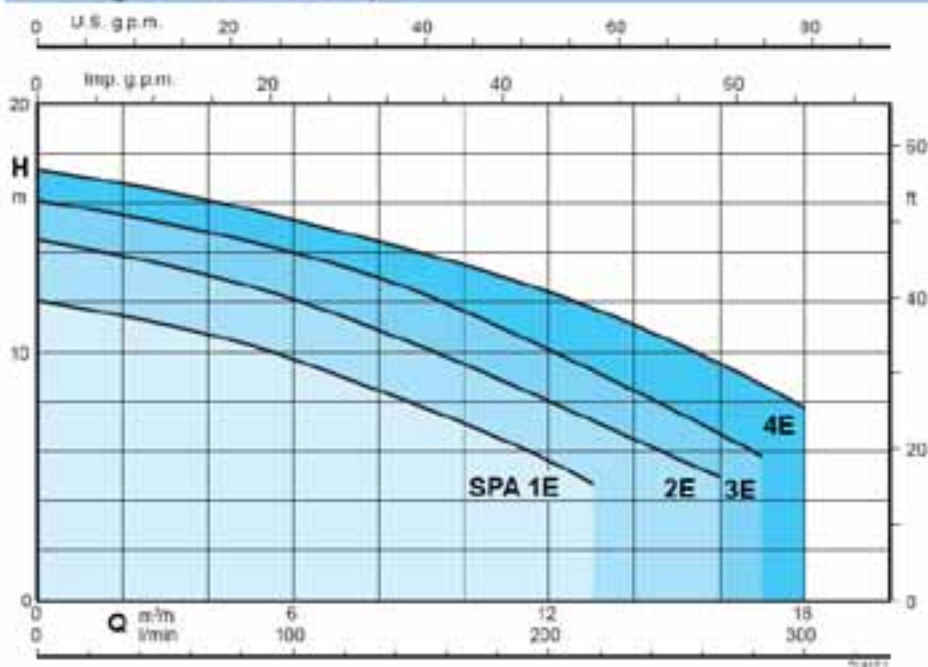

Spa Pump GPS-SPA/SPAM

Technical data GPS-SPA/SPAM

3~	230 V 400 V		1~	230 V		P ₁			P ₂			Q								
	A	A		A	kW	kW	HP	m ³ /h	l/min	0	3	6	9	12	13	16	17	18		
SPA 1E	2,8	1,6	SPAM 1E	3,3	0,73	0,45	0,6	12	11,1	9,7	7,6	5,5	4,7							
SPA 2E	3	1,7	SPAM 2E	4,5	1	0,55	0,75	14,5	13,4	12,1	10,2	7,9	7,2	5						
SPA 3E	3,7	2,2	SPAM 3E	5,4	1,2	0,75	1	16,1	15,2	13,9	12,4	10,2	9,3	6,8	5,8					
SPA 4E	5	2,9	SPAM 4E	7	1,6	1,1	1,5	17,3	16,5	15,3	14	12,4	11,3	9,5	8,6	7,7				

P₁ Max. power input.

P₂ Rated motor power output

H Total head in m.

Tolerances according to ISO 9000, annex A.

Dimensions and weights

TYPE	mm								kg	
	f	L	m3	m1	m2	m3	w	SPA	SPAM	
SPA 1E	333	148	176	34	26	122	161	6,7	5,8	
SPA 2E	315	167	185	39	31	136	166	8	9	
SPA 3E	315	167	185	39	31	136	166	9	10	

SPA 1E, 2E, 3E

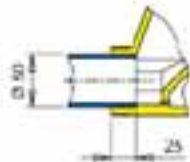
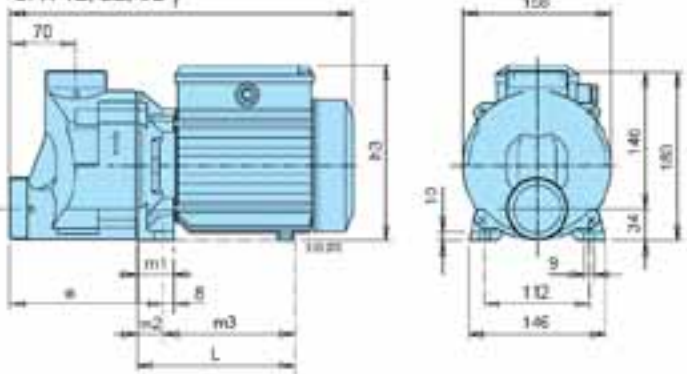

Cemented joint.

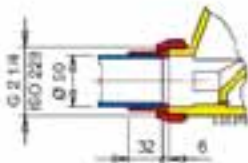

Threaded union coupling.

SPA 4E

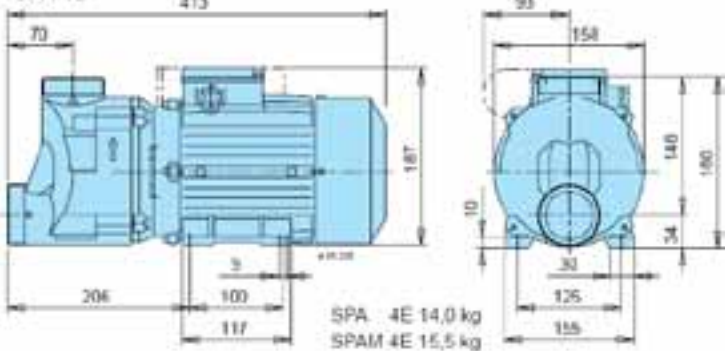

SPA 4E 14,0 kg
SPAM 4E 15,5 kg

Diffuser with peripheral-longitudinal flow, of stainless steel for **extra reliability**.



Mechanical seal without contact with the shaft, for **extra safety**.

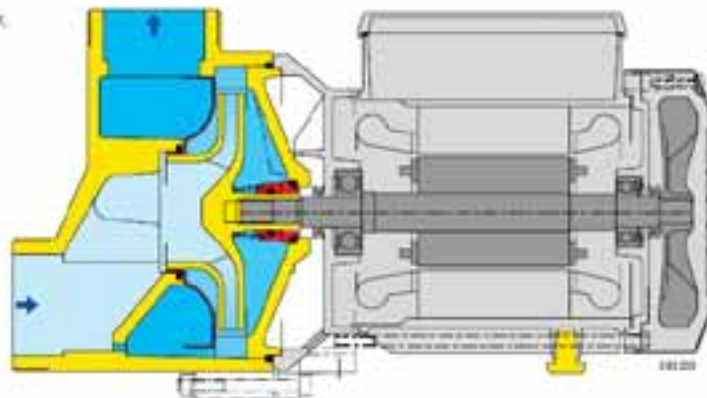

Pool Pump GPS-NMP/NMPM



Construction

Close-coupled self-priming centrifugal pumps with built-in strainer.

Applications

For water circulation in swimming pool filtration systems. For clean or slightly dirty water with solids in suspension.

Operating conditions

Liquid temperature up to 60° C.
Ambient temperature up to 40° C.
Total suction lift up to 7 m.
Maximum permissible working pressure up to 6 bar.
Continuous duty.

Motor

2-pole induction motor, 50 Hz (n = 2900 rpm).

NMP: three-phase 230/400 V ± 10% up to 3 kW,
400/690 V ± 10% from 4 to 11 kW,

NMPM: single-phase 230 V ± 10%, with thermal protector.
Insulation class F.

Protection IP 54.

Constructed in accordance with: IEC 60034

Materials

Components	NMP	B-NMP
Pump casing	Cast iron	Bronze
Lantern bracket	G.JL 200 EN 1561	G-Cu Sn 10 EN 1982
Impeller	Cast iron	Bronze
	G.JL 200 EN 1561	G-Cu Sn 10 EN 1982
	Brass P- Cu Zn 40 Pb 2 UNI 5705 for NMP 32/12	
Shaft	Chrome-nickel steel	Cr-Ni-Mo steel
	1.4305 EN 10088 (AISI 303)	1.4401 EN 10088 (AISI 316)
Strainer cover	Cast iron	Bronze
	G.JL 200 EN 1561	G-Cu Sn 10 EN 1982
Strainer	Chrome-nickel steel 1.4301 EN 10088 (AISI 304)	
Mechanical seal	Carbon - Ceramic - FPM	

Special features on request

- Other voltages.
- Frequency 60 Hz (as per 60 Hz data sheet).
- Protection IP 55.
- Special mechanical seal
- Higher liquid or ambient temperatures.

Technical data GPS-NMP/NMPM

	3 -		1 -	230V		P ₁	P ₂	Q m ³ /h	H m																	
	230V	400V		A	kW				kW	HP	6,5	9,6	10,8	12	13,2	15	18,9	21	24	30	42	48	54	60	66	75
B-NMP 32/12FE	4	3,3						110	160	180	200	220	250	315	350	400	500	700	800	900	1000	1100	1250	1400	1600	1800
			B-NMPM 32/12FE	4,5	0,8	0,55	0,75	13	12	11	10,5	10	9													
B-NMP 32/12DE	4	2,2						12	11	10	9,5	9	8													
			B-NMPM 32/12DE	5,8	1,3	0,75	1	18	17	16	15,5	15	14													
B-NMP 32/12AE	5	2,9						17	16	15	14,5	14	13													
			B-NMPM 32/12AE					22	21	20,5	20	19,5	18,5													
B-NMP 32/12SE	7,5	4,3	B-NMPM 32/12SE	7,4	1,85	1,1	1,5	21,5	20,5	19,5	19	18,5	17,5													
								22,5	21,5	21	20,5	20	19	18*	15*	12*										
B-NMP 50/12HE	5	2,3	B-NMPM 50/12HE	7,4	1,85	1,1	1,5							9	8	8,5	7,5	5,5	4,5	3						
B-NMP 50/12GE	7,5	4,3	B-NMPM 50/12GE	9,2	2	1,5	2							12	12	11,5	10,5	8	7	5	3,5*					
B-NMP 50/12FE	9,15	5,3												16	16	15,5	14,5	12	10,5	8,5	6,5*	5*				
B-NMP 50/12DE	11,5	6,6												18	18	17,5	16,5	15	13	11,5	9,5*	7*				
B-NMP 65/16FE		9,6															18	17	16,5	15,5	14,5	13,5	11,5	9,5	6,5*	
B-NMP 65/16DE		12															20,5	19,5	19	18	17	16	14,5	12,5	9,5*	
B-NMP 65/16FE		16															26	25	24,5	24	23	22	21	19	16*	11*
B-NMP 65/16DE		20															29,5	28,5	28	27,5	27	26,5	25	23,5	20*	16*
B-NMP 65/16AE		24															37,5	36,5	36	35,5	35	34	32,5	30,5	27*	22*

P₁: Maximum power input.

B-NMP = Bronze construction.

* Maximum suction lift 2-3 m.

P₂: Rated motor power output.

H: Total head in m.

Tolerances according to ISO 9906, annex A.

Self priming centrifugal pump GPS-A/AM

Application

For clean or slightly dirty water (with solids up to 10 mm grain size for A 50-125 and 15 mm for A 65-150). For draining a basin or a sump. For irrigation, civil and industrial applications.

Construction

- Close-coupled centrifugal pumps with open impeller.
- The built-in back-flow preventer avoids reverse siphoning when the pump is stopped and assures automatic re-priming at the next start.
- The pump re-priming itself even if partially filled with liquid and with completely empty suction pipe.



Operating conditions

- Liquid temperature from -10 °C to +90 °C.
- Room temperature up to 40 °C.
- Max. working pressure up to 6 bar.
- Continuous duty.

Motor

- 2-pole induction motor, 50 Hz (2900rpm).
- Insulation class F
- Protection IP 54
- Available in bronze on request

Materials

- Pump body - cast iron
- Motor support - cast iron
- Impeller - cast iron
- Shaft with rotor - stainless steel
- Mechanical seal - carbon/ceramic

Technical data GPS-A/AM

3 ~	230 V 400 V		1 ~	230 V		P ₁		P ₂		Q											
	A	A		A	kW	kW	HP	m ³ /h	l/min		6	9	12	15	18	21	24	27	30	33	
A 50-125CE B-A 50-125CE	4	2,3	AM 50-125CE B-AM 50-125CE	5,8	1,2	0,75	1	H _m	13	12,5	11,5	10,5	9,5	8	6	4					
A 50-125BE B-A 50-125BE	5	2,9	AM 50-125BE B-AM 50-125BE	7,4	1,6	1,1	1,5		16	15	14,5	13,5	12	10,5	9	7	5				
A 50-125AE B-A 50-125AE	7,5	4,3	AM 50-125AE B-AM 50-125AE	9,2	2,1	1,5	2		19,5	19	18	17	16	14,5	13	11	9	6			

3 ~	230 V 400 V		P ₂		Q														
	A	A	kW	HP		m ³ /h	l/min	15	18	24	30	33	36	42	48	54	57		
A 65-150CE B-A 65-150CE	9,15	5,3	2,2	3	H _m	250	300	400	500	550	600	700	800	900	950				
A 65-150BE B-A 65-150BE	11,5	6,6	3	4		17,5	17	16	14	13	11,5	9	6,5						
A 65-150AE B-A 65-150AE	16,6	9,6	4	5,5		21,5	21	19,5	17,5	16,5	15,5	12,5	9,5	6,5					

Drainage submersible pump GPS-TS/TSN



Application

Hand-carry submersible automatic water pumps. Able to drain infiltrating water, cellars or reservoirs. Can be used with clean or slightly dirty water and for garden irrigation.

Operating conditions

- Liquid temperature up to 35°C
- Submersion depth 5m
- Grain size inlet
 - TSN 300 3mm
 - TS 400 8mm
 - TS 800 10mm
- Min. suction level
 - TSN 300 15mm
 - TS 400 20mm
 - TS 800 20mm

Motor

- Built-in overload motor protector with automatic reset
- Permanent split capacitor (PSC)
- Insulation class F
- Protection IP 68

Materials

- Handle - moplen
- Pump body - moplen
- Impeller - noryl
- Motor casing - Stainless steel
- Shaft with rotor - Stainless steel
- Seal - double oil seal

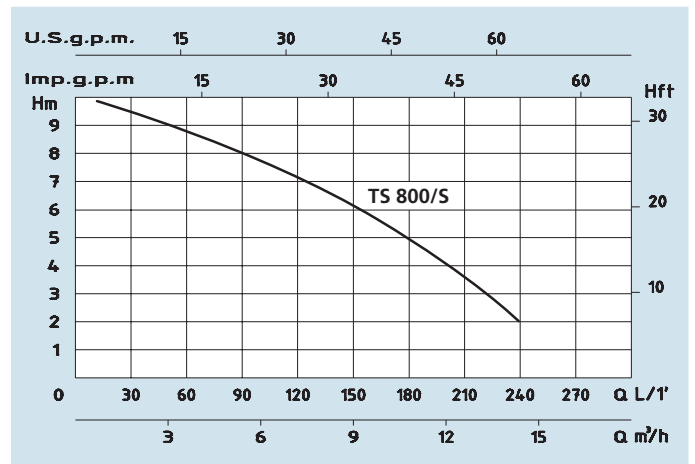
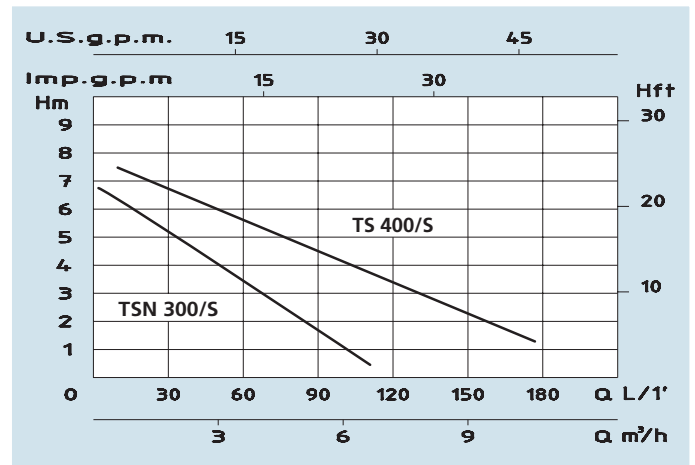

Technical data GPS-TS/TSN

TIPO - TYPE	POTENZA ASSORBITA INPUT POWER P1	AMPERE Monofase Single-phase	Condensatore Capacitor f	Q = PORTATA - CAPACITY																		
				m³/h	0,6	1,2	1,8	2,4	3,6	5,4	8,4	10,8	14,4	18								
Con galleggiante With float switch				lt/1	10	20	30	40	60	90	140	180	240	300								
230V-50Hz	Watt	1 x 230V	f	Prevalenza manometrica totale in m.C.A. - Total head in meters w.c.																		
TSN 300/S	300 W	1,6	5	H (m)	6,3	5,5	5,1	4,3	3	1,3												
TS 400/S	400 W	2	8		7,5	6,8	6,5	6	5,5	4,5	2,3											
TS 800/S	800 W	3,8	20		9,7	9,5	9,2	9	8,7	8	6,6	5	2									

Vortex submersible pump GPS-TF



Application

Hand carry submersible water pumps with vortex impeller suitable to lift waste liquids, even with suspended solids. Able to drain infiltrating water, cesspools or reservoirs. Decanting water from clean, dirty or muddy swimming pools.

Operating conditions

- Liquid temperature up to 35°C
- Submersion depth 5 m
- Grain size inlet 25 mm (TF 400/S)
- Grain size inlet 30 mm
- Min. suction level 40mm

Motor

- Built-in overload motor protector with automatic reset
- Permanent split capacitor (PSC)
- Insulation class F
- Protection IP68

Materials

- Handle - moplen
- Pump body - moplen
- Impeller - noryl
- Motor casing - stainless steel
- Shaft with rotor - stainless steel
- Seal - double oil seal

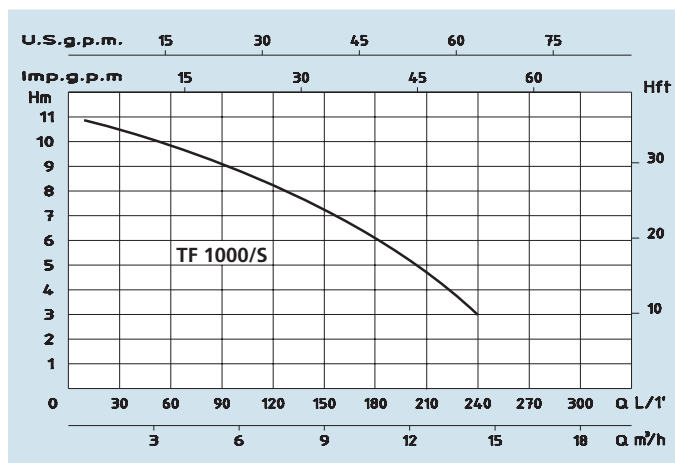
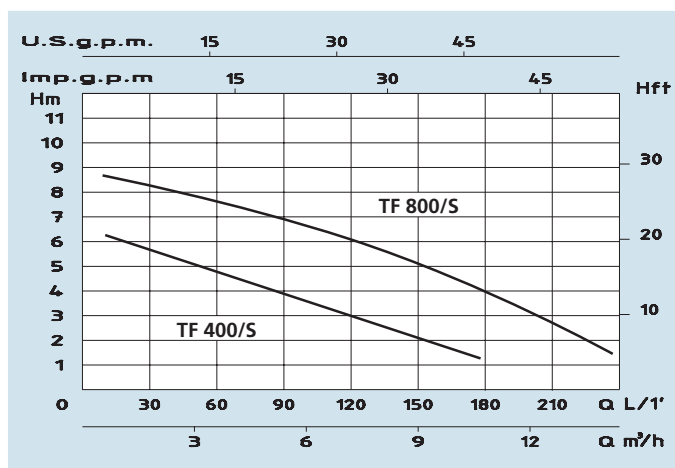

Technical data GPS-TF

TIPO - TYPE	POTENZA ASSORBITA INPUT POWER P1	AMPERE Monofase Single-phase	Condensatore Capacitor f	Q = PORTATA - CAPACITY																
				m³/h	0,6	1,2	1,8	2,4	3,6	5,4	8,4	10,8	14,4	18						
Con galleggiante With float switch				lt/1	10	20	30	40	60	90	140	180	240	300						
230V-50Hz	Watt	1 x 230V		Prevalenza manometrica totale in m.C.A. - Total head in meters w.c.																
TF 400/S	400 W	2	8	H (m)	5,9	5,8	5,7	5,2	4,6	3,9	2,2									
TF 800/S	800 W	3,8	20	H (m)	8,9	8,5	8,2	8	7,8	7	5,6	4								
TF 1000/S	1000 W	4,8	20	H (m)	10,8	10,6	10,3	10,2	10	9	7,5	6	3							

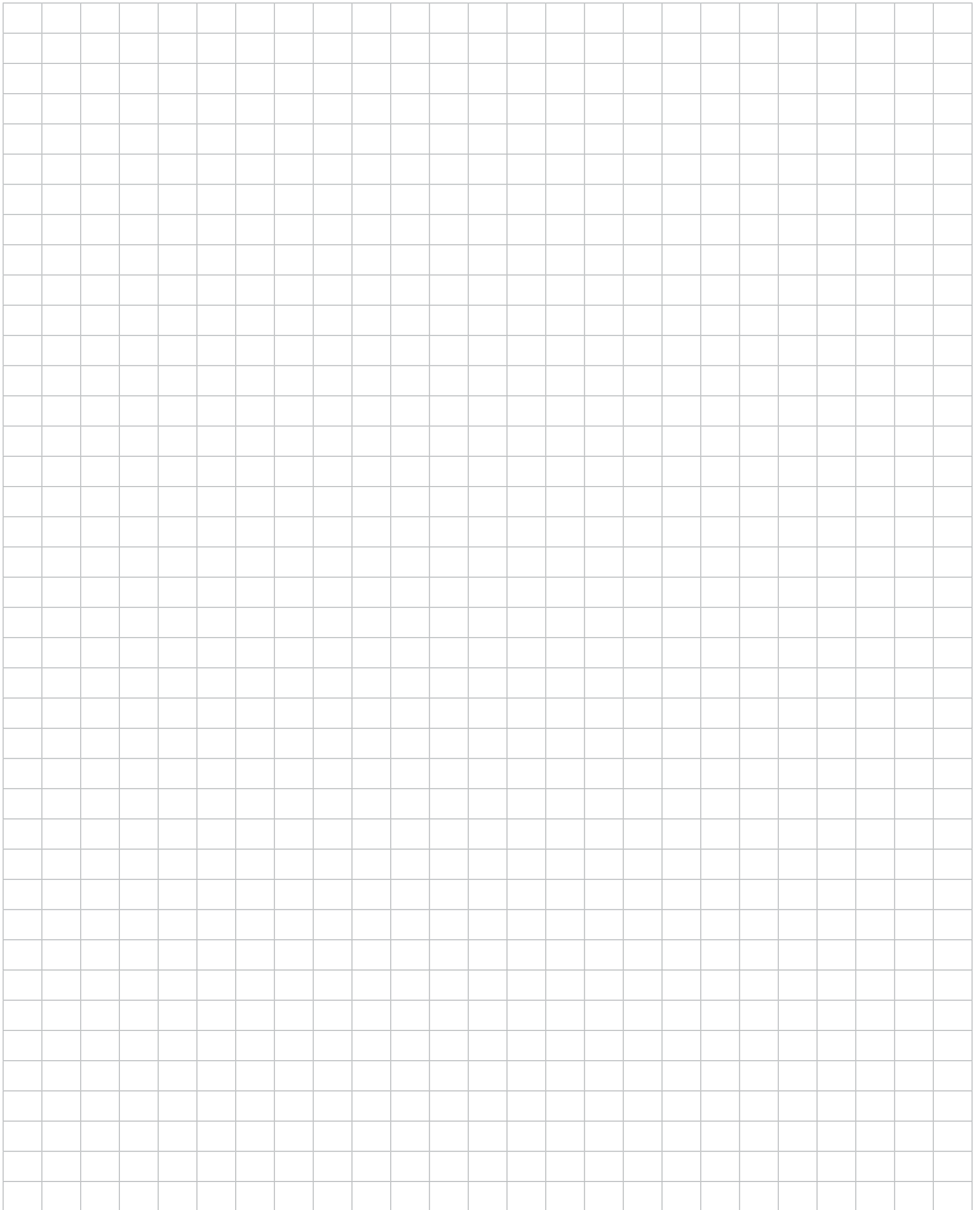

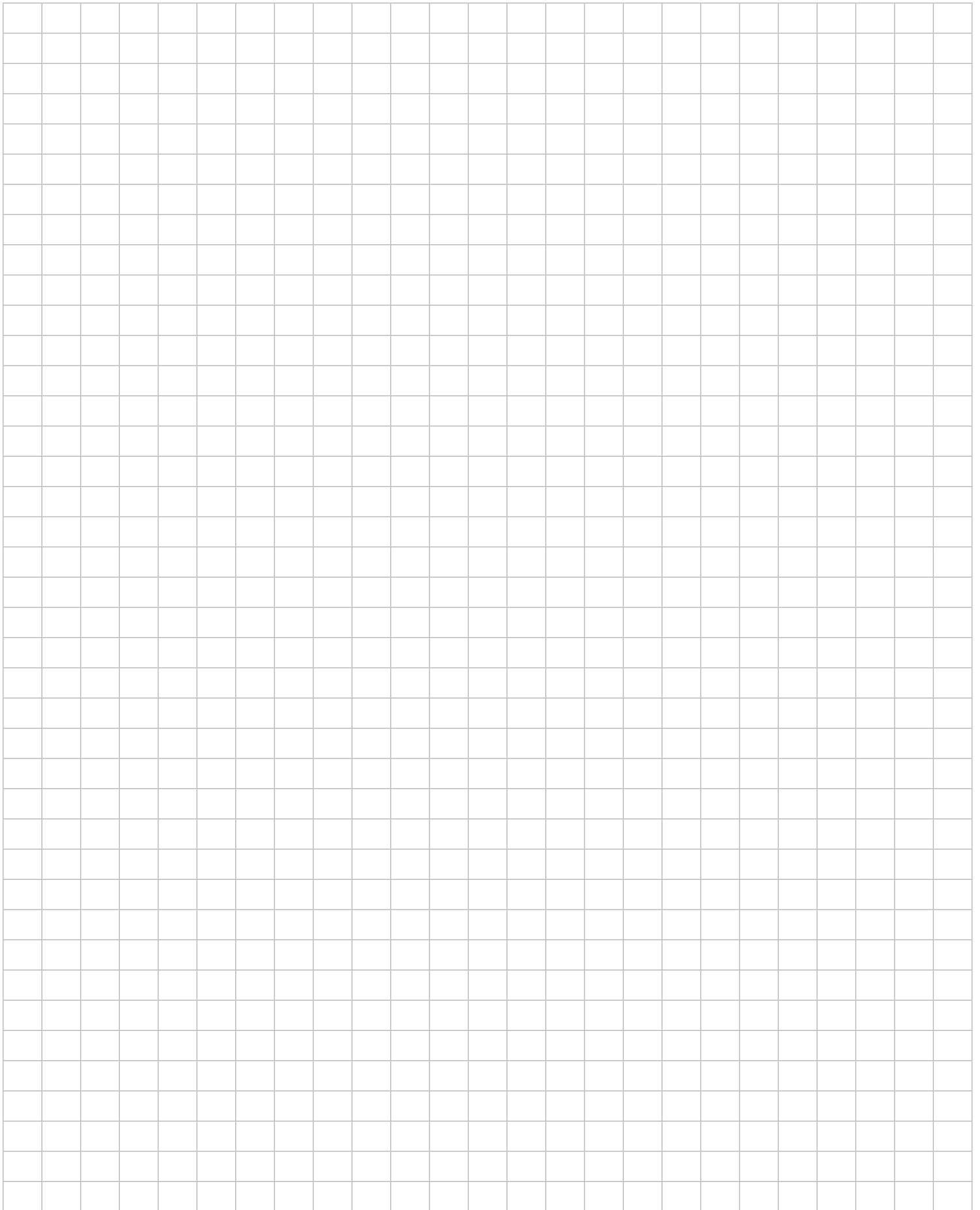



GLOBAL PUMP SOLUTIONS LTD

T +64 9 414 5416
F +64 9 414 5418
E global.pumps@slingshot.co.nz
PO Box 305 143
Triton Plaza, Albany
Auckland, New Zealand

Your local Supplier: